

Technical Introduction to CICS

Ezriel Gross – Rocket Software

Monday, February 23, 1:15pm - 2:15pm

Location: Salon 17

Session: TECH_323

Agenda

What is CICS and Who Uses It

Pseudo Conversational Programming

CICS Application Services

CICS Connectivity

CICS Resource Definitions

CICS Supplied Transactions

CICS Web Services

What is CICS?

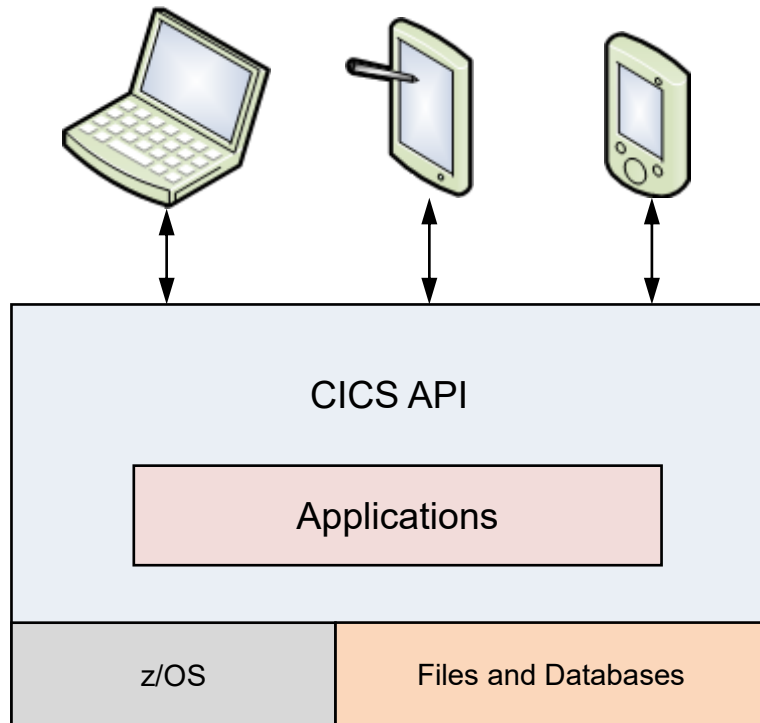

- CICS is an online transaction processing system.
- Middleware between the operating system and business applications.
- Manages the user interface.
- Retrieves and modifies data.
- Handles the communication.

CICS customers

- Banks

- Mortgage
- Account Reconciliations
- Payroll

- Brokerage Houses

- Stock Trading
- Trade Clearing
- Human Resources

- Insurance Companies

- Policy Administration
- Accounts Receivables
- Claims Processing

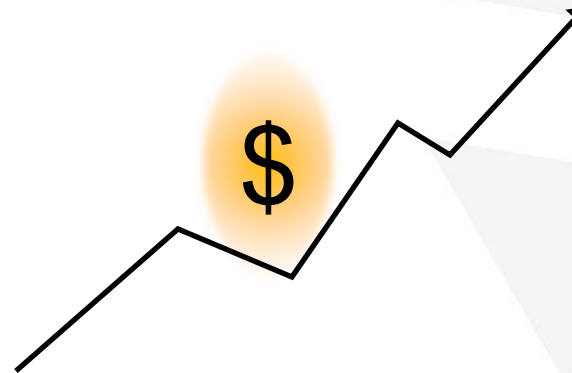
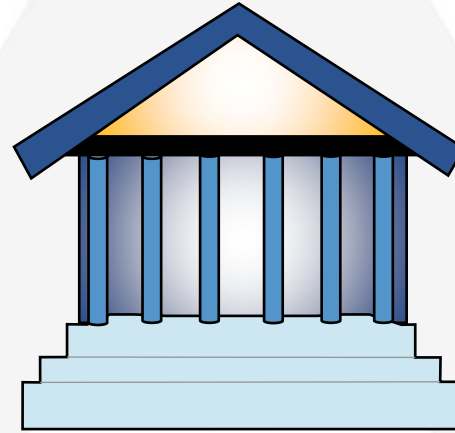

Batch versus online programs

- The two ways to process input are ***batch*** and ***online***.

- **Batch**

- Batch requests are saved then processed *sequentially*.
- After all requests are processed the results are transmitted.
- Used for order entry processing such as warehouse applications.

- **Online**

- Online requests are received randomly and processed *immediately*.
- Results are transmitted as soon as they are available.
- Response time tends to be sub-second.
- Used for applications such as credit card authorization.

Transaction processing requirements

- Large volume of business transactions to be rapidly and accurately processed
- Multiple users, single/sysplex or distributed
- With potentially:
 - A huge number of users
 - Simultaneous access to data
 - A large volume of data residing in multiple database types
- Intense security and data integrity controls necessary
- The access to the data is such that:
 - Each user has the perception of being the sole user of the system
 - A set of changes is guaranteed to be logically consistent
 - If a failure occurs, any intermediate results are undone before the system becomes available again
 - A completed set of changes is immediately visible to other users

A business transaction

- A **transaction** is a sequence of related operations that performs a function
- It might perform a single action
 - Example: Retrieve an account balance
- It can also perform a set of operations:
 - Read credit limits
 - Check if amount of purchase is greater than limit
 - Subtract funds or deny purchases
- A transaction has a 4-character id

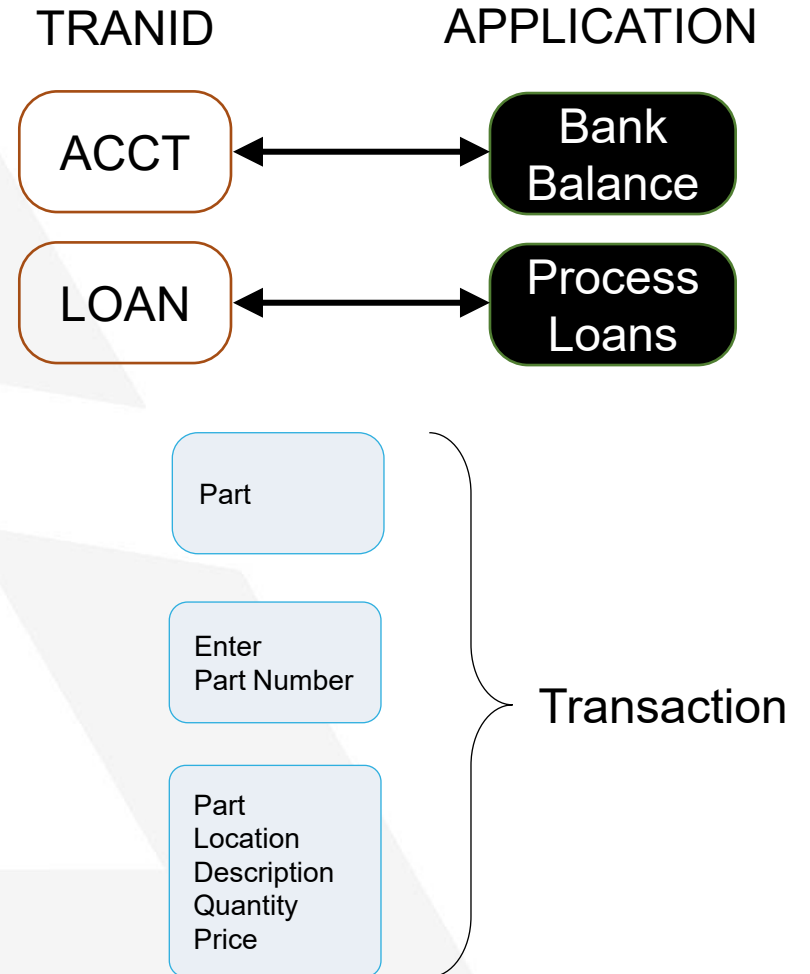

CICS tasks and programs

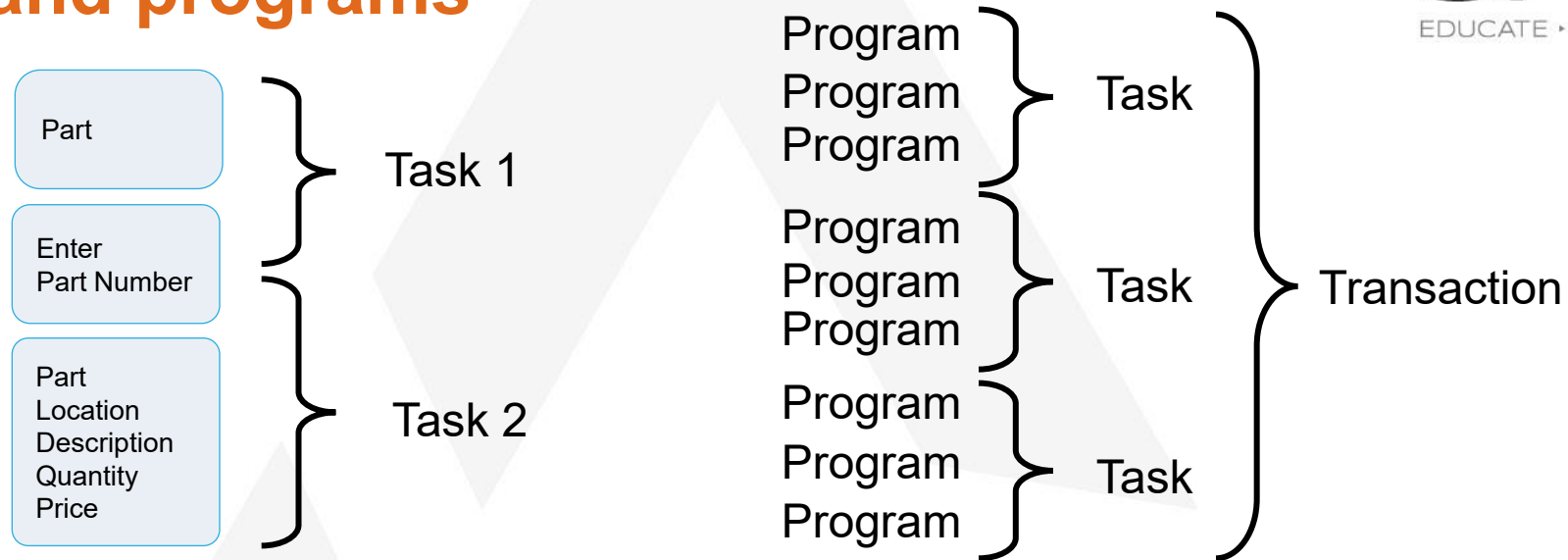

- A **task** is an instance of a transaction entered by a user.
- When a user types in data and presses the Enter or a function key, CICS begins a task and loads the necessary programs.
- Tasks run concurrently. Therefore, a user can run the same transaction simultaneously.
- CICS uses multitasking to provide fast response times.
- Programs can be loaded once and then shared by transactions.
- CICS runs each task individually, briefly giving CPU to each one.
- If a user updates a file or database, the change is immediately available.

Conversational vs pseudo-conversational

- **Conversational** programs...
 - Run and **stay in memory** for the duration of the transaction.
 - All resources are **held/locked** for this duration.
 - If a user went to lunch in the middle of a conversational transaction, other users **may have to wait!**
- **Pseudo-conversational** programs...
 - Overcome this by **terminating** when the first response is produced.
 - Usually when the 3270 screen is displayed.
 - This frees up the resource should the user go to lunch.
 - A transaction is re-started when the user presses the Enter or a function key.
 - This involves more difficult program design (but is well worth it).
 - *Most applications are coded in a **pseudo-conversational** manner.*

Application development

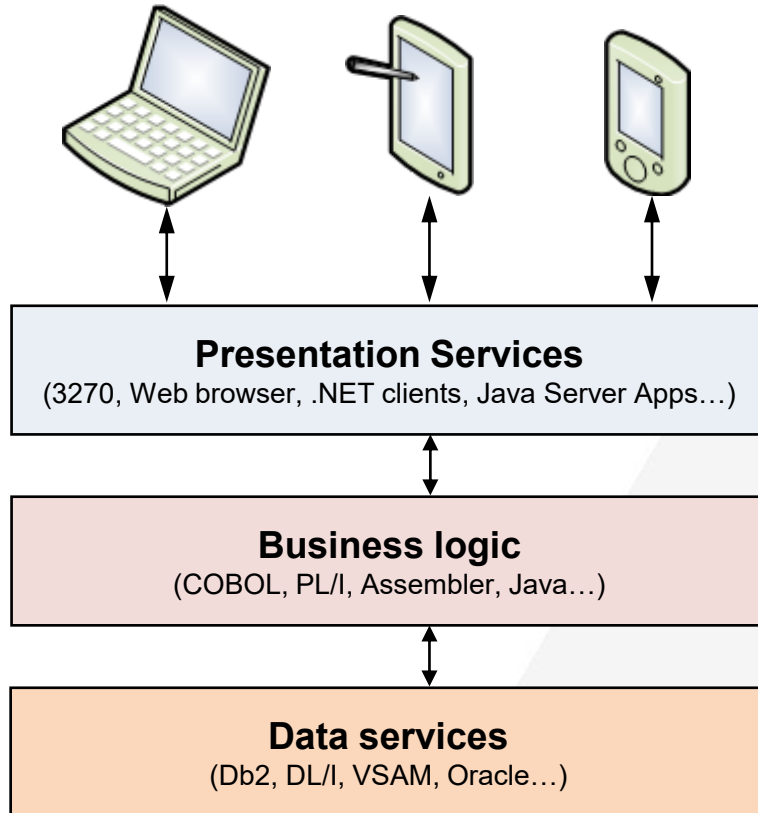

- CICS application programs are *generally* divided into 3 categories:
 - **Presentation services:** communication between users and the transaction processing system.
 - **Business logic:** data manipulation and computation required by the transaction (most of processing).
 - **Data services:** retrieve/update data.
- **Benefits of separation:**
 - Components can be invoked/reused by other applications.
 - Allows for plug and play component changes when necessary.
 - Business transactions can mix and match program languages and data types.

Application services

- The **CICS API** allows programmers to request services using EXEC CICS commands.
- Many programming languages are supported in the CICS environment.
- CICS provides built-in transactions to assist the programmer with development.
 - **CEDF / CEDX**: Execution diagnostic facility transactions. Provides interactive debugging.
 - **CADP / DTCN**: Provides access to the CICS Debug Tool, a Source Level Debugger supplied with LE370.
 - **CECI**: Command interpreter transaction. Allows EXEC CICS statements without coding a program.
 - **CEBR**: Allows a programmer to browse through CICS Temporary Storage or Transient Data Queues.
 - **CMAC**: CICS Message and Codes online transaction.

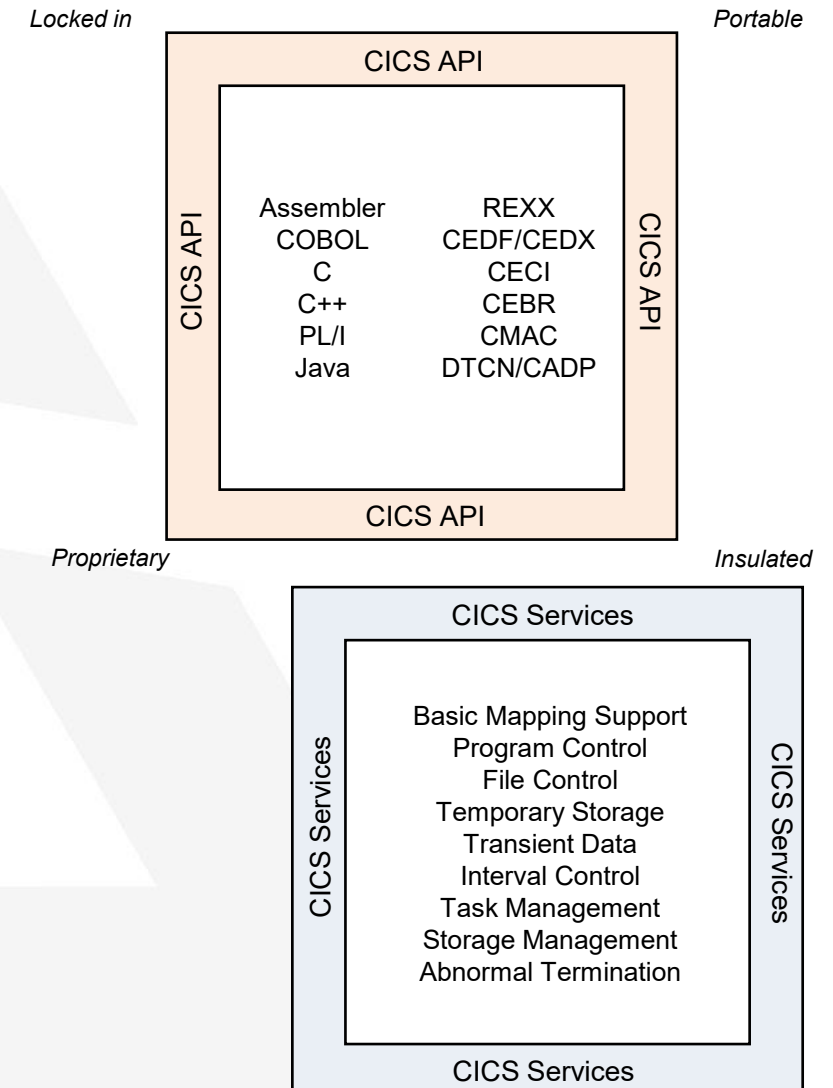

EXEC interface

- CICS command format

- The general format of CICS commands for the COBOL language is:

```
EXEC CICS
    FUNCTION
    OPTION (Argument)
END-EXEC
```

where:

- FUNCTION: Describes the CICS operation
- OPTION: Describes the options available with each function
- ARGUMENT: A data value used to qualify the option

- CICS programs look like batch with the insertion of EXEC (execute) CICS commands.
- The CICS commands are used to request services.
- CICS commands must be translated into COBOL prior/during program compilation.

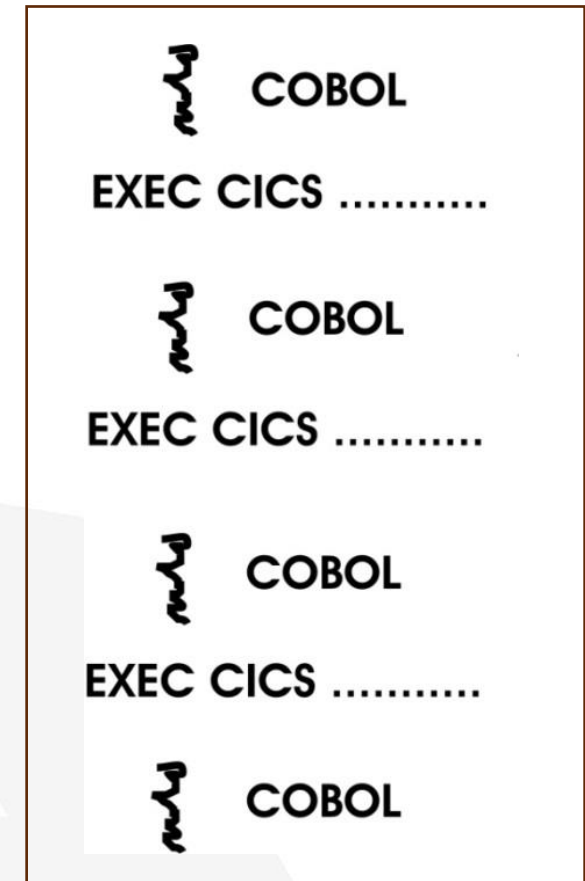

Integrated translator

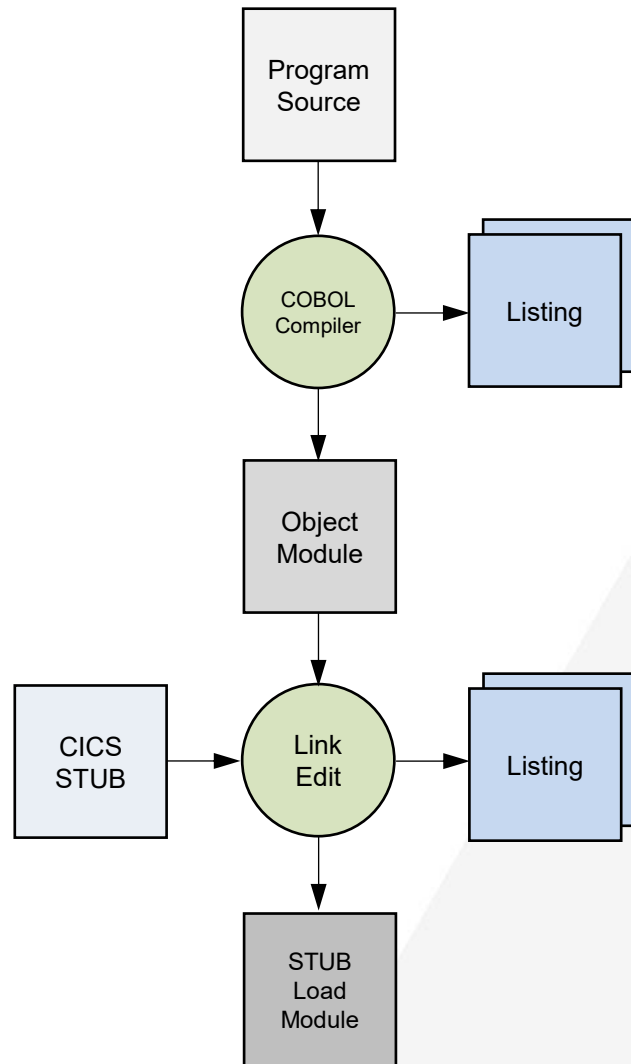

- Translation integrated into the compiler
 - In the past, this was a step prior to compilation
- The CICS command is commented out and replaced with valid COBOL statements
- The stub is link-edited with the load module and it is used to find the **DFHEIP** program

Before translation

```

EXEC CICS READ
  FILE ('STOCK')
  RIDFLD(KEY)
  INTO(INPUT-AREA)
  UPDATE
  RESP(WS-RESP)
END-EXEC

MOVE INPUT-AREA TO...
  
```

After translation

```

*EXEC CICS READ
*      FILE ('STOCK')
*      RIDFLD(KEY)
*      INTO(INPUT-AREA)
*      UPDATE
*      RESP(WS-RESP)
*END-EXEC

CALL DFEHI1 USING...

MOVE INPUT-AREA TO...
  
```

Execution flow

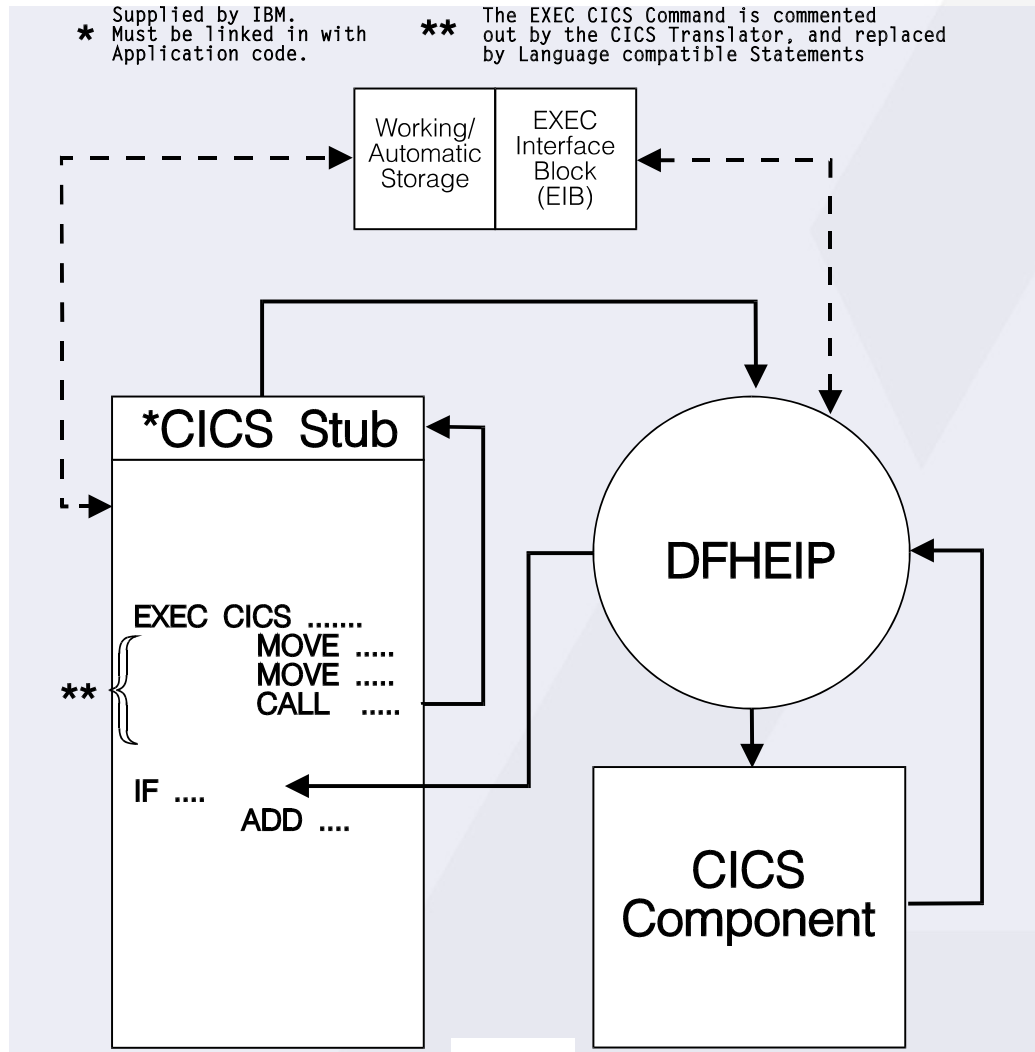

- The program **DFHEIP** gives control to the management module that will satisfy the request.
- The EXEC Interface Block (EIB) copybook contains fields to pass data and receive responses from CICS.
- The EIB is read-only. The contents should not be modified.

EIB fields

NAME	COBOL	PL/I	C	ASM	DESCRIPTION
EIBTIME	PIC S9(7)comp-3	FIX DEC(7,0)	char[4]	PL4	TIME IN OHHMMSS FORMAT
EIBDATE	PIC S9(7)comp-3	FIX DEC(7,0)	char[4]	PL4	DATE IN OCYYDDD FORMAT
EIBTRNID	PIC X(4)	CHAR(4)	char[4]	CL4	TRANSACTION IDENTIFIER
EIBTASKN	PIC S9(7)comp-3	FIX DEC(7,0)	char[4]	PL4	TASK NUMBER
EIBTRMID	PIC X(4)	CHAR(4)	char[4]	CL4	TERMINAL IDENTIFIER
EIBRSVDI	PIC XX	CHAR(2)	char[2]	CL2	RESERVED
EIBCPOSN	PIC S9(4)comp	FIX BIN(15)	signed short	H	CURSOR POSITION
EIBCALEN	PIC S9(4)comp	FIX BIN(15)	signed short	H	COMMAREA LENGTH
EIBAID	PIC X	CHAR(1)	char	CL1	ATTENTION IDENTIFIER
EIBFN	PIC XX	CHAR(2)	char[2]	CL2	FUNCTION CODE
EIBRCODE	PIC X(6)	CHAR(6)	char[6]	CL6	RESPONSE CODE
EIBDS	PIC X(8)	CHAR(8)	char[8]	CL8	DATASET NAME
EIBREQID	PIC X(8)	CHAR(8)	char[8]	CL8	REQUEST IDENTIFIER
EIBRSRCE	PIC X(8)	CHAR(8)	char[8]	CL8	RESOURCE NAME
EIBSYNC	PIC X	CHAR(1)	char	CL1	X'FF' SYNCPOINT REQUESTED
EIBFREE	PIC X	CHAR(1)	char	CL1	X'FF' FREE REQUESTED
EIBRECV	PIC X	CHAR(1)	char	CL1	X'FF' RECEIVE REQUIRED
EIBSEND	PIC X	CHAR(1)	char	CL1	RESERVED
EIBATT	PIC X	CHAR(1)	char	CL1	X'FF' ATTACH RECEIVED
EIBEOC	PIC X	CHAR(1)	char	CL1	X'FF' EOC RECEIVED
EIBFMH	PIC X	CHAR(1)	char	CL1	X'FF' FMHS RECEIVED
EIBCOMPL	PIC X	CHAR(1)	char	CL1	X'FF' DATA COMPLETE
EIBSIG	PIC X	CHAR(1)	char	CL1	X'FF' SIGNAL RECEIVED
EIBCONF	PIC X	CHAR(1)	char	CL1	X'FF' CONFIRM REQUESTED
EIBERR	PIC X	CHAR(1)	char	CL1	X'FF' ERROR RECEIVED
EIBERRCD	PIC X(4)	CHAR(4)	char[4]	CL4	ERROR CODE RECEIVED
EIBSYNRB	PIC X	CHAR(1)	char	CL1	X'FF' SYNC ROLLBACK REQ'D
EIBNODAT	PIC X	CHAR(1)	char	CL1	X'FF' NO APPL DATA RECEIVED
EIBRESP	PIC S9(8) comp	FIX BIN(31)	signed long	F	CONDITION NUMBER
EIBRESP2	PIC S9(8) comp	FIX BIN(31)	signed long	F	Additional details for some Responses
EIBRLDBK	PIC X	CHAR(1)	char	CL1	ROLLED BACK

Passing data between programs

```

File Edit Edit_Settings Menu Utilities Compilers Test Help
EDIT CIRCS.CWI.CIRCS03(P03RECV2) - 01.09 Columns 00001 00072
Command ==> Scroll ==> CSR
000001 linkage section.
000002
000003 01 ls-commarea.
000004 02 ls-comm-key.
000005 03 ls-comm-dept pic 9.
000006 03 ls-comm-emp pic 9(5).
000007 03 filler PIC 9(2).
000008 02 ls-comm-count pic s9(8) comp.
000009 02 ls-comm-recs pic x(3000).
000010 .
000011 .
000012 .
000013 procedure division.
000014
000015 exec cics link
000016 program ('BROWSLNK')
000017 commarea(ls-commarea)
000018 length(length of ls-commarea)
000019 resp(ws-resp)
000020 end-exec.
:00.1 04/15

```

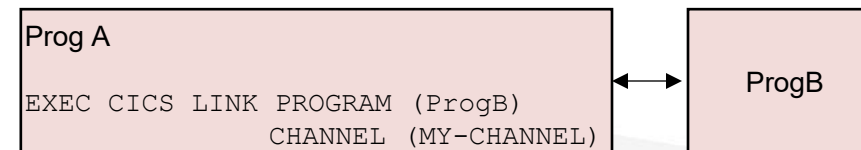
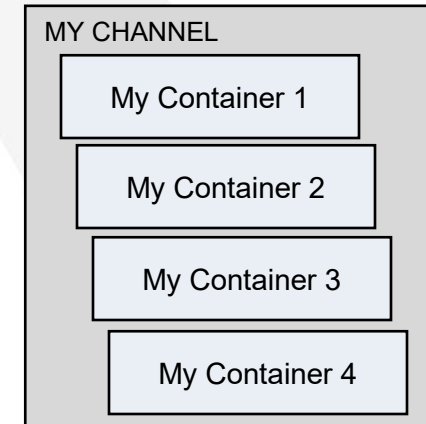

- Communicate via **channels and containers** or via **COMMAREA**
- **Channels and containers**
 - Unlimited number of containers in a channel, unlimited amount of data per container
- **COMMAREA:**
 - Older style of communication
 - Maximum size is 32K: if more was needed temporary storage was often used

CICS connectivity

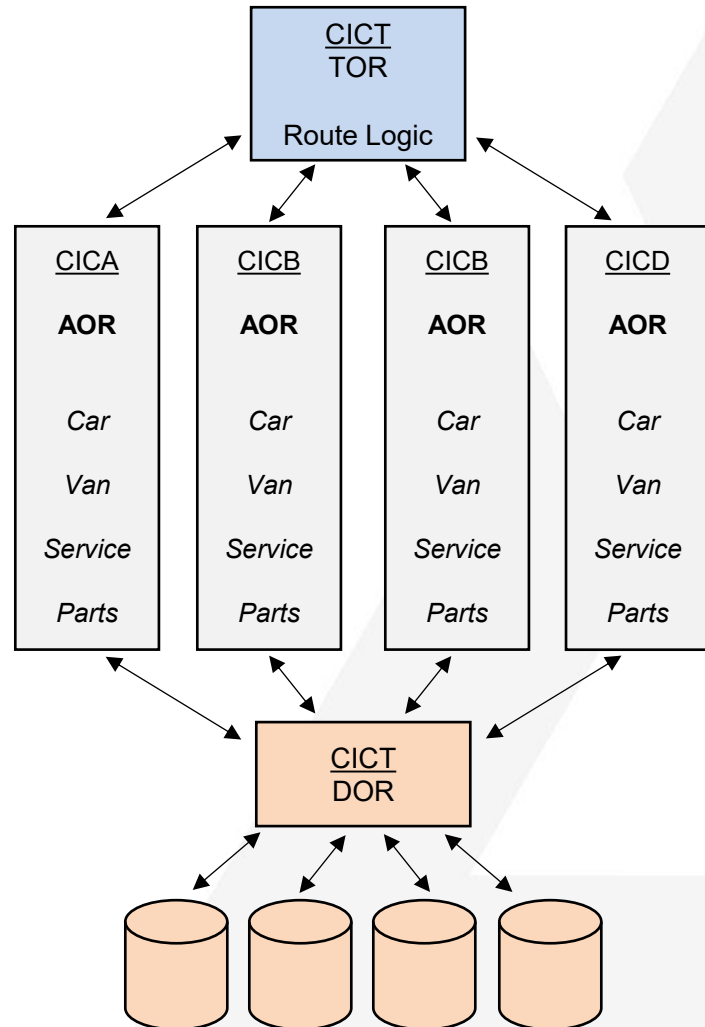

- Multiregion operation (MRO)
- Intersystem communication (ISC)
- External CICS interface (EXCI)
- External Call Interface (ECI)
- External Presentation Interface (EPI)
- Web Support / Services (TCP/IP)

Communications

Feature	Function
Transaction Routing	Allows users from terminals connected in one CICS System to run transactions in another CICS system.
Function Shipping	Allows a CICS Transaction in one system to access the resources owned by a connected CICS system.
Asynchronous Processing	Allows distributed processing of an application asynchronously, and can be used cross system.
Distributed Program Link (DPL)	Allows a program to link to another program in a remotely connected system.
External CICS Interface (EXCI)	Enables an MVS Batch Program to call a program in a CICS region. Same as External Call Interface (ECI), but with ECI the call is made from another platform.
External Presentation Interface (EPI)	Allows a program running on another platform to emulate a 3270 terminal into CICS.
Web Support / Services	Allows applications running on other platforms to communicate using a SOAP / XML message in an HTTP format over TCP/IP with CICS programs.

CICS resources

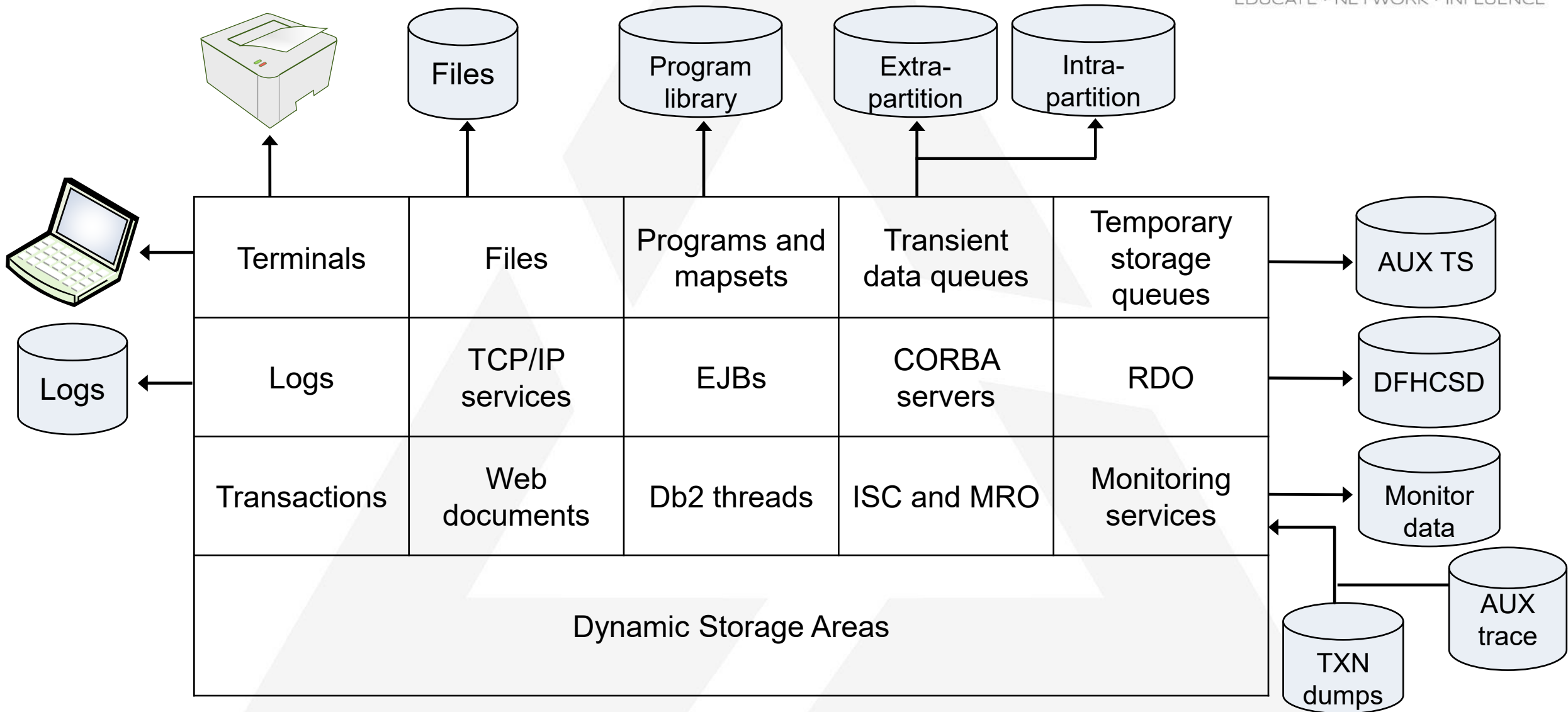

CICS system definitions

- Resource Definitions are descriptions of resource types.
 - Example: The name of a transaction and the first program to execute.
- Resource Definitions provide CICS with the information to recognize and manipulate data appropriately.
- The information in the resource definitions may also contain the properties and interactions between resources.
- If a resource is not defined or defined incorrectly to CICS, it may not be recognized or cause errors and Transaction failures.
- Resource definitions are mostly stored on the CICS System Definition (CSD) File.

Methods for resource definition

- **Resource Definition Online (RDO)**
 - Uses CICS supplied transactions (CEDA, CEDB and CEDC) while a CICS region is running, to make definitions that are stored in the CICS System Definition (CSD) file.
- **DFHCSDUP Offline Utility**
 - Operates like RDO, but offline through a batch job.
- **Automatic Installation (Autoinstall)**
 - Works only with user modifications through a definition model. The utility then dynamically creates new definitions based on the model which can prevent the manual creation of large numbers of definitions.
- **System programming**
 - Using the EXEC CICS CREATE command, creates resources that are independent of the CSD.
- **Macro Definition**
 - Using assembler macros, creates definitions and stores them in assembled tables in a program library. The definitions are installed during CICS initialization.

Resource Definition Online (RDO)

CEDA DEF

ENTER ONE OF THE FOLLOWING

Atomservice	MQConn	Urimap
Bundle	MQMonitor	Webservice
CONNECTION	PARTitionset	
CORbaserver	PARTner	
DB2Conn	PIpeline	
DB2Entry	PROcesstype	
DB2Tran	PROfile	
DJar	PROGram	
DOctemplate	Requestmodel	
Enqmodel	Sessions	
File	TCpipservice	
Ipconn	TDqueue	
JOurnalmodel	TERminal	
JVmserver	TRANClass	
Library	TRANSACTION	
LSrpool	TSmodel	
MApset	TYpeterm	

SYSID=R54G APPLID=CCVR54G

PF 1 HELP

3 END

6 CRSR

9 MSG

12 CNCL

CEMT - CICS Master Terminal

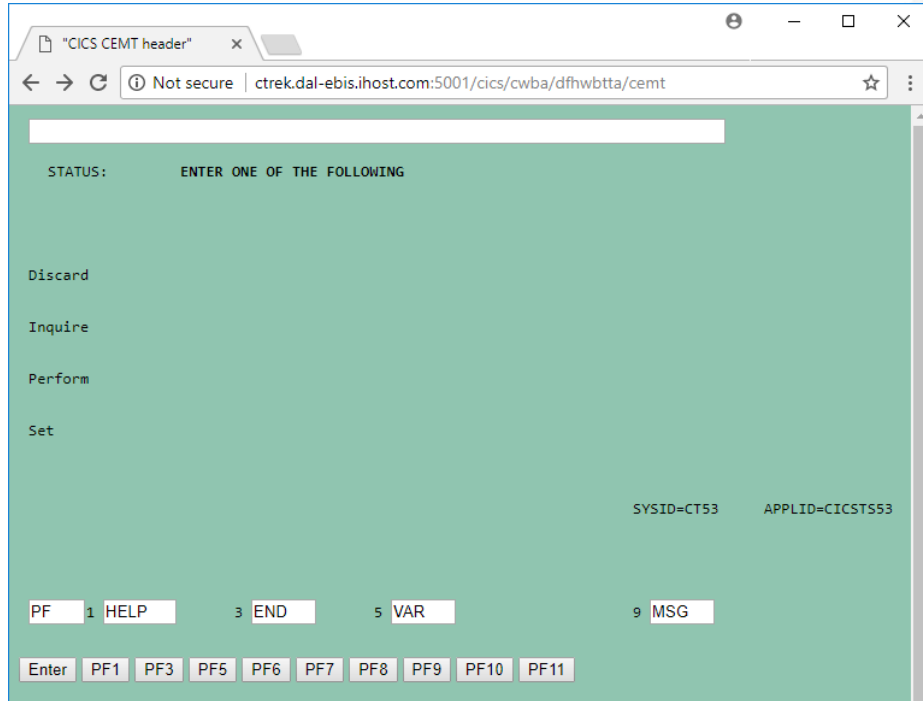

```
I TRANSACTION(TREK)
RESULT - OVERTYPE TO MODIFY
Transaction(TREK)
Priority( 255 )
Program(KVPKVEW)
Tclass( DFHTCL00 )
Status( Enabled )
Availstatus(Notapplic)
Routing(Static)
Routestatus(Notroutable)
Purgeability( Purgeable )
Prfile(DFHCICST)
Taskdatakey(Cdatakey)
Taskdataloc(Any)
Isolatest(Isolate)
Trprof()
Indoubt(Backout)
Indoubtwait(Wait)
Brexit()
+ Facilitylike()
```

```
SYSID=WABC APPLID=CCVWABC
TIME: 14.50.52 DATE: 01/31/18
PF 1 HELP 2 HEX 3 END 5 VAR 7 SBH 8 SFH 10 SB 11 SF
```

- The CICS Master Terminal (CEMT) transaction can be used to get information about resources and their definitions.
- CEMT has four commands and can be used to alter resource definitions that have already been installed in CICS.
- Only some attributes of a resource may be changed using CEMT, others require complete re-installation.

Access to CICS

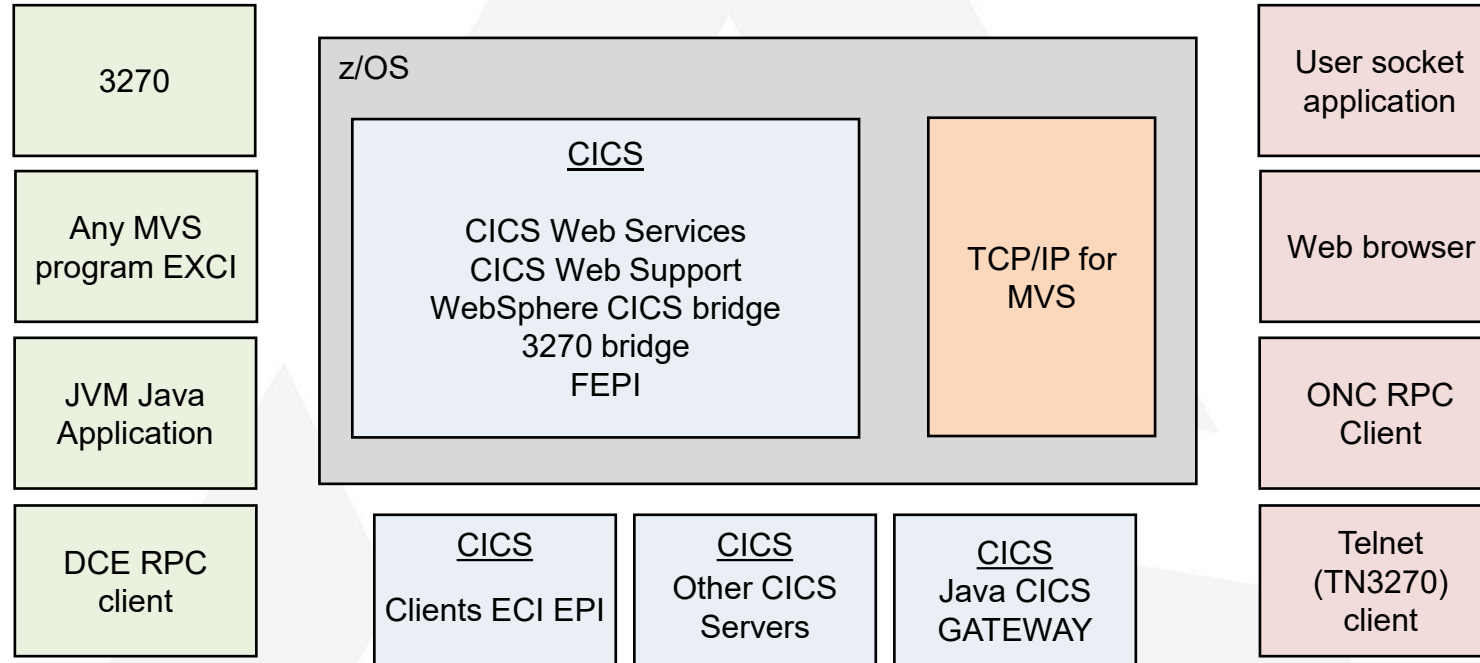

- CICS provides access to applications from a variety of sources.
- Client applications can be developed on any platform and in any language.
- CICS can also be used as a client to other applications running on different platforms.

CICS web applications

The screenshot shows a web browser window with the following content:

- Browser Tab:** Circle CICS/TS 1.3 Menu
- Address Bar:** ctrek.dal-ebis.ihost.com:5002/cics/cwba/t13txt2/tocfram3.html
- Left Sidebar (CICS Web Support menu):**
 - 0 Samples
 - 1 CICS books
 - 2 3270 Bridge
 - 2.1 JFUL
 - 2.2 CEMT
 - 3 Web Sites
 - 4 Miscellaneous
- Main Content Area:**
 - Title:** Example CICS web applications
 - Text:** CICS On the WEB
 - Image:** A cartoon illustration of two aliens sitting in a striped chair, looking at a computer monitor displaying a web page.
 - Userid:** CICSUS53
 - Navigation:** [Top](#) [Next](#)
 - Copyright:** Copyright © Circle Computer Group

CICS web services

- Described by **Web Services Definition Language (WSDL)**
- CICS can be a service **requestor** or **provider** in a SOA environment
- CICS provides utilities to assist in:
 - Converting applications into web services
 - Accessing web services from external providers
- **CICS TS Feature Pack for Mobile Extensions:**
 - Adds support for web service requests using **JavaScript Object Notation (JSON)** and the conversion between JSON and high-level language data structures

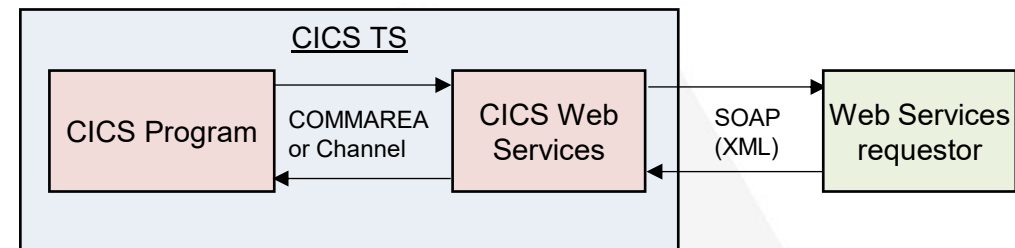
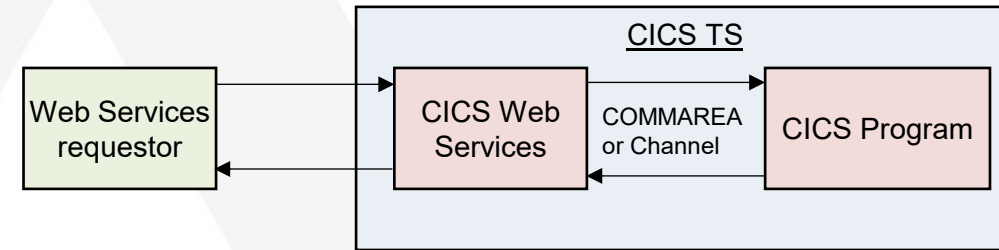

CICS Service Oriented Architecture (SOA)

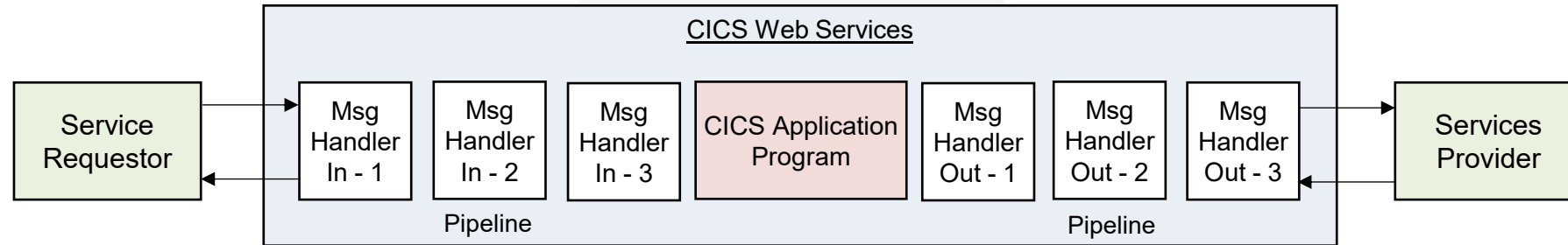

- Integrated into most current release
- Defined by **Web Service Description Language (WSDL)**
- CICS role in SOA can be service **requestor**, service **provider**, or both
- **CICS Web Services utility programs**
 - Assist in converting existing application into a Web Service
 - Use a Web Service provided by an external provider
- Support for web services standards and technologies
 - WSDL 2.0
 - WS-I Basic Profile 1.1
 - WS-Security
 - WS-Trust
 - WS-Addressing
 - Message Transmission Optimization Mechanism /XML – Binary Optimized Packaging (MTOM/XOP)

CICS event processing

- An **event** is anything of significance to an enterprise
- CICS allows users to capture, format and emit **business events** from CICS
- Events can be sent via HTTP, MQ queue, TS Queue or Start Transaction for further processing
- Events are bound to a CICS system using an **event binding editor** built into **CICS Explorer** and Rational Developer for System z with Java (**RDz**)
- The bindings are enabled using a **BUNDLE** resource
 - **CICS Explorer** or Web User Interface (WUI)
 - RDO or CEMT

CICS Explorer plug-in

The screenshot displays the IBM CICS Explorer application window. The title bar reads "IBM CICS Explorer - C:/Documents and Settings/EzrieU.cicsexplorer". The interface includes a menu bar (File, Edit, Project, Operations, Definitions, Search, Window, Help) and a toolbar. The main area is divided into several panes:

- Left Pane:** A tree view showing the CICSplex structure. The selected node is "CCVPLEXH (4/7)", which contains sub-nodes like "CCVDAOR1 (CCVDAOR1)", "CCVDAOR2 (CCVDAOR2)", "CCVDEMO (CCVDEMO)", "CCVDFOR1", "CCVDTOR (CCVDTOR)", "CCVT42M", and "CCVT42T". Below these are groups for AORs (AORG, FORG, TORG) and various CICSplex resources (CCVPLXH2, EDUPLX99, EYUPLX01, OPCNTPLX, TESTPLX1).
- Top Right Pane:** Shows the current context: "CNX02111 Context: CCVPLEXH, Resource: TASK, 15 records collected at Nov 2, 2012 12:08:00 PM". It includes input fields for "Transaction ID:" and "Task ID:".
- Table:** A table listing transaction records with the following columns: Transacti..., Region, Task ID, Run Status, User ID, Terminal ID, LU Name, Priority, Class Name, and Suspend ...
- Bottom Pane:** Contains "Connections" and "Credentials" sections. The "Connections" section shows a tree of CICS System Management (4) and CICS Management Interface (3) components, including "FUNDI SM [EJG@116]", "CTREK SM [SYSEGX0@204]", and "FUNDI SM - Internal [EJG (2)@116]". The "Credentials" section lists "SYSEGX0@204 [SYSEGX0]", "EJG (2)@116 [EJG]", and "EJG@116 [EJG]".
- Status Bar:** At the bottom, it shows "IZE01001 Connected user EJG to host 116.212.215.58 on port 11828" and the current user "FUNDI SM".

CICS Visual Studio Code Extension

The screenshot displays the Visual Studio Code interface with the CICS Visual Studio Code extension. The left sidebar shows the ZOWE EXPLORER with a tree view of data sets and CICS regions. The main editor displays a COBOL program with syntax-highlighted code. The bottom panel shows a terminal window with Windows command prompt output.

```
TS5162.CICSWS.COBO(LPARTPROG).cbl 1 x
> extensions > zowe.vscode-extension-for-zowe-2.2.0 > resources > temp > _D_ > RS02 > TS5162.CICSWS.COBO(LPARTPROG)
5  000500 WORKING-STORAGE SECTION.                                00050015
6  000600 01  RESPONSE          PIC S9(8) COMP.                    00060015
7  000700 01  IN-MSG.                                                00070015
8  000800 02  TRANS-ID         PIC X(4)  VALUE SPACES.              00080017
9  000900 02  FILLER           PIC X.                                00090015
10 001000 02  INPUT-PART       PIC X(5)  VALUE SPACES.              00100016
11 001100 01  PART-DATA.                                              00110015
12 001200 02  PART-NUM        PIC X(5).                               00120015
13 001300 02  PART-LOC        PIC X(20).                             00130015
14 001400 02  PART-DESC       PIC X(55).                             00140015
15 001500 01  OUT-MSG.                                                00150015
16 001600 02  OUTPUT-PART     PIC X(5).                               00160015
17 001700 02  FILLER          PIC X(12) VALUE ' LOXATION '.          00170032
18 001800 02  OUTPUT-LOC     PIC X(20).                             00180015
19 001900 02  FILLER          PIC X(15) VALUE ' DESCRIPTION '.       00190023
20 002000 02  OUTPUT-DESC    PIC X(55).                             00200023

TERMINAL  PROBLEMS 1  OUTPUT  DEBUG CONSOLE
Microsoft Windows [Version 10.0.19042.1826]
(c) Microsoft Corporation. All rights reserved.

C:\Users\egross>
```

CICS tools

- If CICS does not provide the needed functionality there are many tools available from IBM and other vendors to assist in creating and managing an online transaction processing system.
- For example, IBM provides the following:
 - CICS Batch Application Control
 - CICS Configuration Manager for z/OS
 - CICS Interdependency Analyzer
 - CICS VSAM Recovery for z/OS
 - CICS Performance Analyzer for z/OS
 - CICS VSAM Transparency
 - IBM OMEGAMON for CICS on z/OS
 - REXX for CICS Transaction Server for VSE/ESA
 - IBM Knowledge Center
- Many tools also provide a CICS Explorer plug-in.

New in CICS TS 5.6

New and enhanced features in CICS TS V5.6 include:

- New support for Pivotal Spring Boot, Jakarta EE 8
- Enhanced CICS Java API
- New Maven Central libraries for CICS Java application development
- New plug-ins for Maven and Gradle to automate building CICS bundles
- New deployment API to simplify CICS bundle deployment during development
- New support for Node.js version 12
- Enhanced support for CICS TS as an HTTP client when using TLS
- Improved reporting and action for z/OS short-on-storage conditions
- Support for COMMAREAs up to 32 KB on distributed program links
- New and enhanced system programming interfaces to assist with JVM server administration

New in CICS TS 6.1

New and enhanced features in CICS TS V6.1 include:

- Support for Java™ 11, Jakarta Enterprise Edition 9.1, and Eclipse MicroProfile 5
- Bundle deployment and multi-factor authentication (MFA) supported in single CICS regions
- CICS resource configuration with application source using the CICS resource builder
- New support for Transportation Layer Security (TLS) 1.3
- New CICS health checks for IBM Health Checker for z/OS
- New protection to guard against executing code in data-only memory
- Resource definition overrides
- Improved temporary storage expiry processing
- Advanced CICS Explorer functions in single CICS regions
- CICS installation using z/OSMF Software Management

New in CICS TS 6.2

New and enhanced features in CICS TS V6.2 include:

- **Java 17 support:** Available via IBM Semeru Runtime Certified Edition for z/OS 17.0.7.0+.
- **Jakarta EE 10 and Spring Boot 3 support:** Enables modern, lightweight app development with optimized access to CICS services.
- **Node.js 18 support:** Via IBM Open Enterprise SDK for Node.js 18, with optimized API accessNew support for Transportation Layer Security (TLS) 1.3.
- **CICS TS Resource Builder 1.0.4:** Supports CICS TS 6.2 and new resource attributes.
- **Security discovery tooling:** Collects and analyzes existing CICS region security usage for zero trust strategy alignment.
- **User-defined transactions:** New transactions default to RESSEC(YES) and CMDSEC(YES).
- **TLS 1.3 sysplex caching:** Now supported; enhances SSL session sharing across regions.
- **Threadsafe shared data table reads:** Improves concurrency for read-only commands.
- **Reduced SMF statistics:** Avoids writing zero-count data, reducing SMF volume.
- **Threadsafe shared data table reads:** Improves concurrency for read-only commands.

New in CICS TS 6.3

New and enhanced features in CICS TS V6.3 include:

- **AI Agent Support:** Provides pre-built AI agents that utilize the Model Context Protocol (MCP) to help Large Language Models (LLMs) gather real-time, contextual information about a CICS environment without needing an administrator interface.
- **AIOps Insights:** Enhancements for faster incident management through AI-driven insights.
- **Language Support:** Updated support for modern languages, including Java 21, Jakarta EE 10, MicroProfile 6.1, and Spring Boot 3.
- **OpenTelemetry:** Native support for OpenTelemetry Java, allowing developers to generate and collect telemetry data within JVM servers for better visibility into application performance.
- **Enhanced Credential Management:** Zowe Explorer for CICS allows immediate updating of credentials, including multi-factor authentication.
- **SSL Certificate Authentication:** Improved security for CICS Management Client Interface (CMCI) connections.
- **Guardium AI Security:** Integration to manage the security risks of AI usage.
- **Configuration Simplification:** Tools designed to simplify the management and configuration of CICS systems.
- **JVM Endpoint Actions:** Ability to enable/disable JVM endpoints on-the-fly to speed up testing cycles.
- **Resource Management:** Improved CICS Resource Inspector with highlighted attributes for faster troubleshooting.
- **TS Queue Management:** Dedicated view for Transactions Specific (TS) and Shared TS queues to improve monitoring.
- **Performance Monitoring:** Support for monitoring the Transaction Rate of the Quasi-Reentrant (QR) TCB.

Summary

- CICS is ideal for existing transactional environments and your new ones too.
- Attributes of CICS:
 - Availability, Maintainability, and Scalability.
 - Tools for Development, Support and Operation.
 - Continues exploitation of new hardware and software technology.
 - Plenty of education is available.

Further reading

Reading	URL
CICS Product Information	http://www.ibm.com/software/htp/cics/
CICS Transaction Server Knowledge Center	http://www.ibm.com/support/knowledgecenter/SSGMGV
IBM Redbooks	http://www.redbooks.ibm.com/
Lists available training courses and certifications	https://www.ibm.com/it-infrastructure/z/education
CICS SupportPacs (downloadable code and documentation)	http://www.ibm.com/support/docview.wss?uid=swg27007241
CICS Explorer	https://www.ibm.com/au-en/marketplace/cics-explorer

Further reading: IBM Redbooks

Redbook title	URL
Introduction to CICS Dynamic Scripting	http://www.redbooks.ibm.com/abstracts/sg247924.html
Threadsafe Considerations for CICS	http://www.redbooks.ibm.com/abstracts/sg246351.html
Extend the CICS Explorer: A Better Way to Manage Your CICS	http://www.redbooks.ibm.com/abstracts/sg247819.html
IBM CICS and the JVM server: Developing and Deploying Java Applications	http://www.redbooks.ibm.com/abstracts/sg248038.html
Implementing CICS Web Services	http://www.redbooks.ibm.com/abstracts/SG247206.html
Exploring Systems Monitoring for CICS Transaction Gateway	http://www.redbooks.ibm.com/abstracts/sg247562.html
CICS Web Services Workload Management and Availability	http://www.redbooks.ibm.com/abstracts/sg247144.html
CICS Systems Manager in the WUI as the Principal Management Interface	http://www.redbooks.ibm.com/abstracts/sg246793.html

Contact Information

- Ezriel Gross' Email egross@rocketsoftware.com
- Website www.rocketsoftware.com
- Phone Office 781-684-2672
- Phone Cell 201-707-2786

Your feedback is important!

Submit a session evaluation for each session you attend:

www.share.org/evaluation

