

# The IMS Common Service Layer (CSL) Not So Common After All

Ashley Lopez  
ashlopez@ibm.com  
Technical Enablement Specialist  
Z Ecosystem Infrastructure & WSC Advisory

- +
  - • **What does your IMS look like?**







# What is an IMSplex?

- An IMSplex is a set of IMS address spaces that are working together as a unit and are most likely running in a parallel sysplex (but not required)
  - Examples of an IMSplex configuration include:
    - A set of IMS control regions
  - Examples of IMSplex components are:
    - IMS subsystems (DB/DC, DBCTL, DCCTL)
    - IMS Connect
    - CSL components (OM, RM, SCI, ODBM)
    - A batch or DB utility region using DBRC
- 



# Common Service Layer (CSL) Overview



- An architecture to improve the systems management capabilities for IMS systems
    - Structured Call Interface
    - Operations management (Operations Manager)
    - Resource management (Resource Manager)
    - IMS Database access (Open Database Manager)
  - Provides
    - A single system image (IMSplex)
    - Ease of use through a single point of control
    - Shared resources across all IMS systems
  - Reduces complexity of managing multiple IMS systems
- 

+

•

○

# IMS Common Service Layer (CSL) – Why?

## Type 2 commands

- Single point of Control to IMS Plexed systems
- Batch commands
- ISPF command entry with history

## IMS Plex routing or global commands

## Dynamic Resource Definitions

## Open Database Manager

## DDL leverages DRD for New resource creation

+  
◦ • Common  
◦ Service  
◦ Layer  
◦ (CSL)  
◦ Managers

- Operations Manager (OM)
- Resource Manager (RM)
- Structured Call Interface (SCI)
- Open Database Manager (ODBM)
- Based on BPE (Base Primitive Environment)
- Address spaces
  - OM, RM, SCI, ODBM



# Base Primitive Environment (BPE)

- All CSL address spaces execute BPEINI00
- Add BPEINI00 to the z/OS Program Properties Table (PPT)
- Two BPE PROCLIB members
  - Contain trace level and user exit information
  - BPE Configuration Parameters (BPECFG=BPExxxxx)
  - BPE User Exit List
    - EXITMBR= in BPECFG=
      - EXITDEF= in EXITMBR
  - Neither are required
    - Can let BPE configuration parameters default
    - Do not need user exits
- All IMSplex members can share the BPE PROCLIB members

# CSL Definition with BPE – High Level View

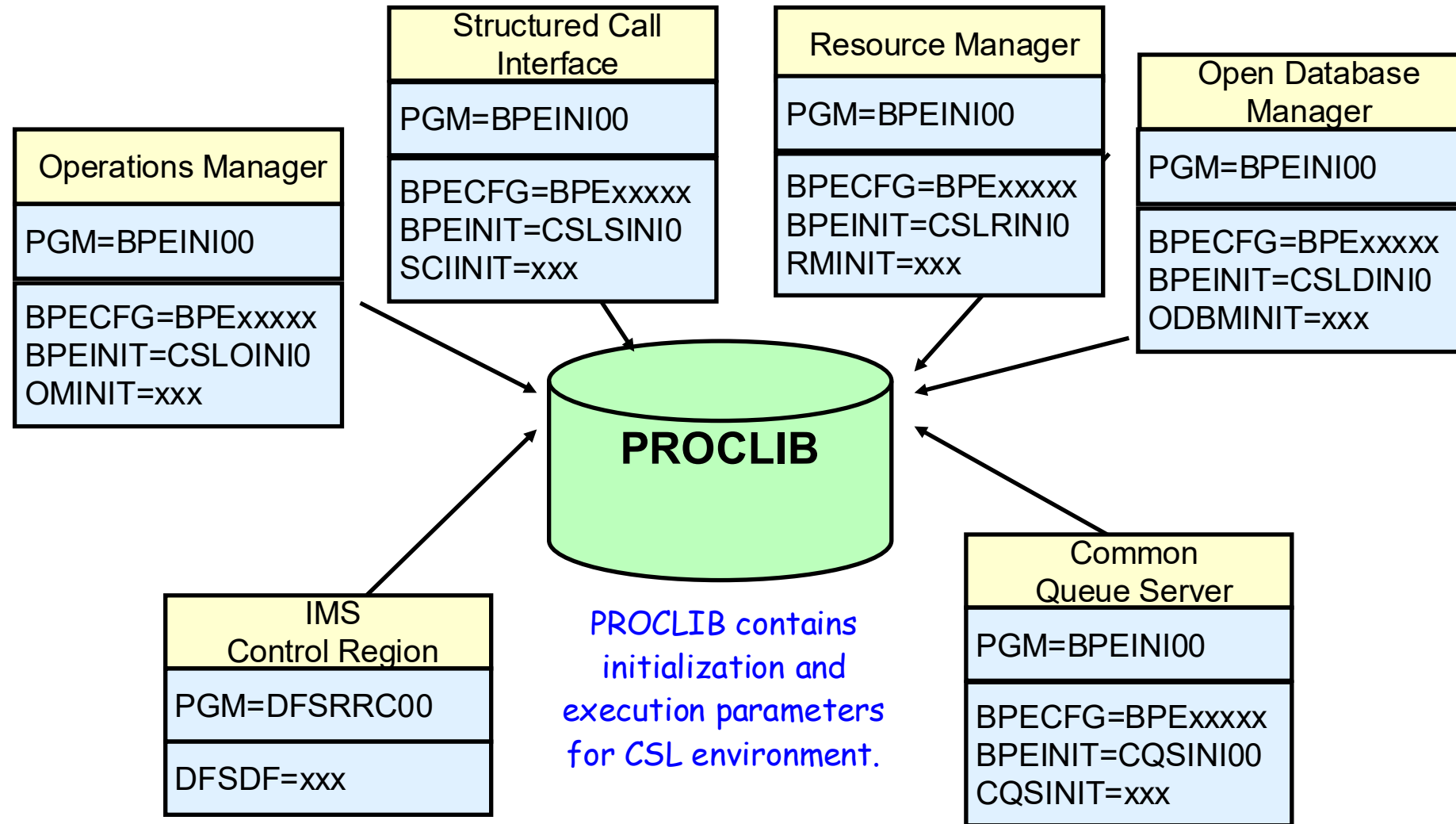

+

•

○

# Structure Call Interface Why?

- Provides communications services among IMSplex members in a single z/OS image and across multiple z/OS images in an IMSplex
- One SCI address space is required on each z/OS image where CSL is active

# Structured Call Interface Setup

- One SCI address space is required on every z/OS image where CSL is active
- SCI started task JCL found in IMS.PROCLIB (CSLSCI)
- Each SCI address space:
  - Executes BPEINI00 - SCI initialization module
    - BPEINIT=CSLSINI0
  - SCI PROCLIB member CSLSIxxx
    - SCIINIT=xxx
- Each instance of SCI has a different initialization PROCLIB member to specify its unique SCI name (and IMSplex name)

# CSL Architecture – Structured Call Interface

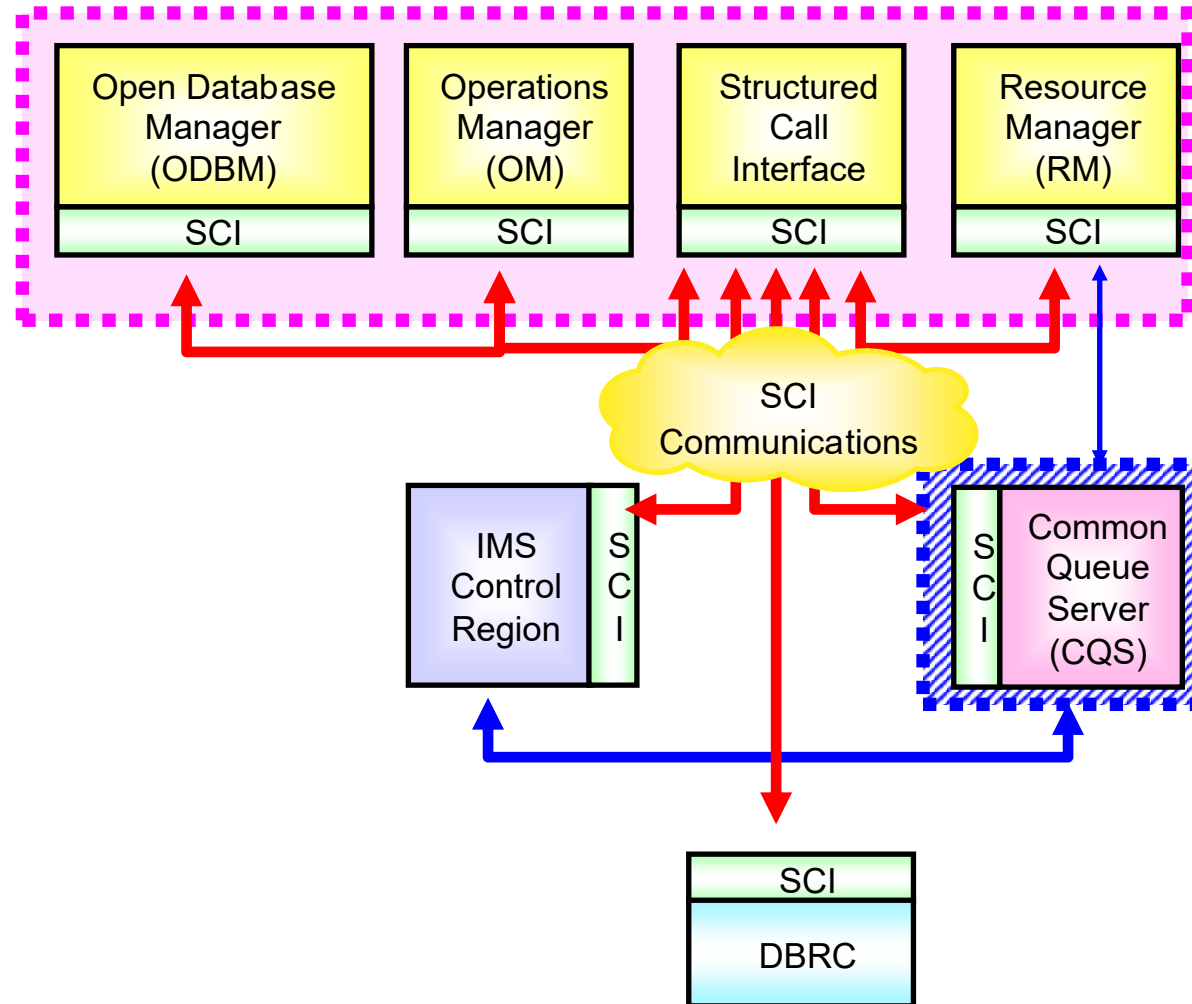

# IMS Structure Call Interface – Started Task JCL

```
EDIT          SVTSC.PROCLIB(IMS15SCI) - 01.05          Columns 00001 00072
Command ==>                                         Scroll ==> CSR
000011 //IEFPROC EXEC PGM=BPEINI00,REGION=3000K
000012 // PARM=( 'BPECFG=BPECONFIG', 'BPEINIT=CSLSINI0', 'SCIINIT=000',
000013 //          'ARRRST=N', 'SCINAME=SCI1' )
000014 /**
000015 //STEPLIB DD DSN=DFSF10.USER.SDFSRESL,DISP=SHR
000016 //          DD DSN=DFSF10.SDFSRESL,DISP=SHR
000017 //PROCLIB DD DSN=VENDOR.PROCLIB,DISP=SHR
000018 //          DD DSN=SVTSC.PROCLIB,DISP=SHR
000019 //          DD DSN=DFSF10.PROCLIB,DISP=SHR
000020 /**
000021 //SYSPRINT DD SYSOUT=*
000022 //SYSUDUMP DD SYSOUT=*
000023 /**
000024 /**
***** ***** Bottom of Data *****
```

# IMS Structure Call Interface – Infrastructure

```
EDIT          DFSF10.PROCLIB(CSLSI000) - 01.00          Columns 00001 00072
Command ==>           Scroll ==> CSR
***** Top of Data *****
000001 *-----*
000002 * SCI INITIALIZATION PROCLIB MEMBER.          *
000003 *-----*
000004 ARMRST=N,          /* SHOULD ARM RESTART SCI ON FAILURE */
000005 SCINAME=SCI1,          /* SCI NAME (SCIID = SCI1SCI) */
000006 IMSPLEX(NAME=PLEX1)          /* IMSPLEX NAME (CSLPLEX1) */
000007 *-----*
000008 * END OF MEMBER CSLSI000          *
000009 *-----*
***** Bottom of Data *****
```

+

•

○

# Operations Manager Why?

- Provides the functions:
  - Type-2 commands enablement
  - Communication between IMS components
  - Consolidate command responses into a single response to present to the command originator
  - Command security for authorization using RACF or equivalent plus user exit
  - User exit capability for editing command input and responses
- A focal point for the “Single Point of Control” (SPOC), an ISPF interface
  - ‘Aim’ commands to IMS Systems
  - ‘Spray’ commands to an entire IMS plex

# Operations Manager Setup

- An OM address space is required on at least one z/OS image where CSL is active
- Recommend a second OM for backup
- OM started task JCL found in IMS.PROCLIB (CSL0M)
- Each OM address space:
  - Executes BPEINI00
  - OM initialization module
    - BPEINIT=CSLOINI0
  - OM PROCLIB member CSLOIxxx
    - OMINIT=xxx
- Each instance of OM has a different initialization PROCLIB member to specify its unique OM name (and IMSplex name)

# IMS Operations Manager – Started Task JCL

```
EDIT          SVTSC.PROCLIB(IMS150M1) - 01.00          Columns 00001 00072
Command ==>                                         Scroll ==> CSR
000013 //IEFPROC EXEC PGM=BPEINI00,REGION=3000K,
000014 // PARM=( 'BPECFG=BPECONFIG', 'BPEINIT=CSLOINI0', 'OMINIT=000',
000015 //          'ARMRST=N', 'CMDSEC=N', 'OMNAME=OM1' )
000016 //*
000017 //STEPLIB DD DSN=DFSF10.USER.SDFSRESL,DISP=SHR
000018 //          DD DSN=DFSF10.SDFSRESL,DISP=SHR
000019 //*
000020 //PROCLIB DD DSN=VENDOR.PROCLIB,DISP=SHR
000021 //          DD DSN=SVTSC.PROCLIB,DISP=SHR
000022 //          DD DSN=DFSF10.PROCLIB,DISP=SHR
000023 //*
000024 //SYSPRINT DD SYSOUT=*
000025 //SYSUDUMP DD SYSOUT=*
000026 //*
***** ***** Bottom of Data *****
```

# IMS Operations Manager – Infrastructure

```
EDIT          DFSF10.PROCLIB(CSLOI000) - 01.00          Columns 00001 00072
Command ==>                                Scroll ==> CSR
***** Top of Data *****
000001 *-----*
000002 * OM INITIALIZATION PROCLIB MEMBER - CSLOI000 *
000003 *-----*
000004 ARMRST=N, /* SHOULD ARM RESTART OM ON FAILURE */
000005 CMDLANG=ENU, /* USE ENGLISH FOR COMMMAND DESC */
000006 CMDSEC=N, /* NO COMMAND SECURITY */
000007 OMNAME=OM1, /* OM NAME (OMID = OM10M) */
000008 IMSPLEX(
000009     NAME=PLEX1, /* IMSPLEX NAME (CSLPLEX1) */
000010     AUDITLOG=SYSLOG.OM2Q01.LOG), /* MVS LOG STREAM */
000011 CMDTEXTDSN=DFSF10.SDFSDATA /* CMD TEXT DATASET */
000012 *-----*
000013 * END OF MEMBER CSLOI000 *
000014 *-----*
***** Bottom of Data *****
```

# CSL Architecture – Operations Manager (OM)

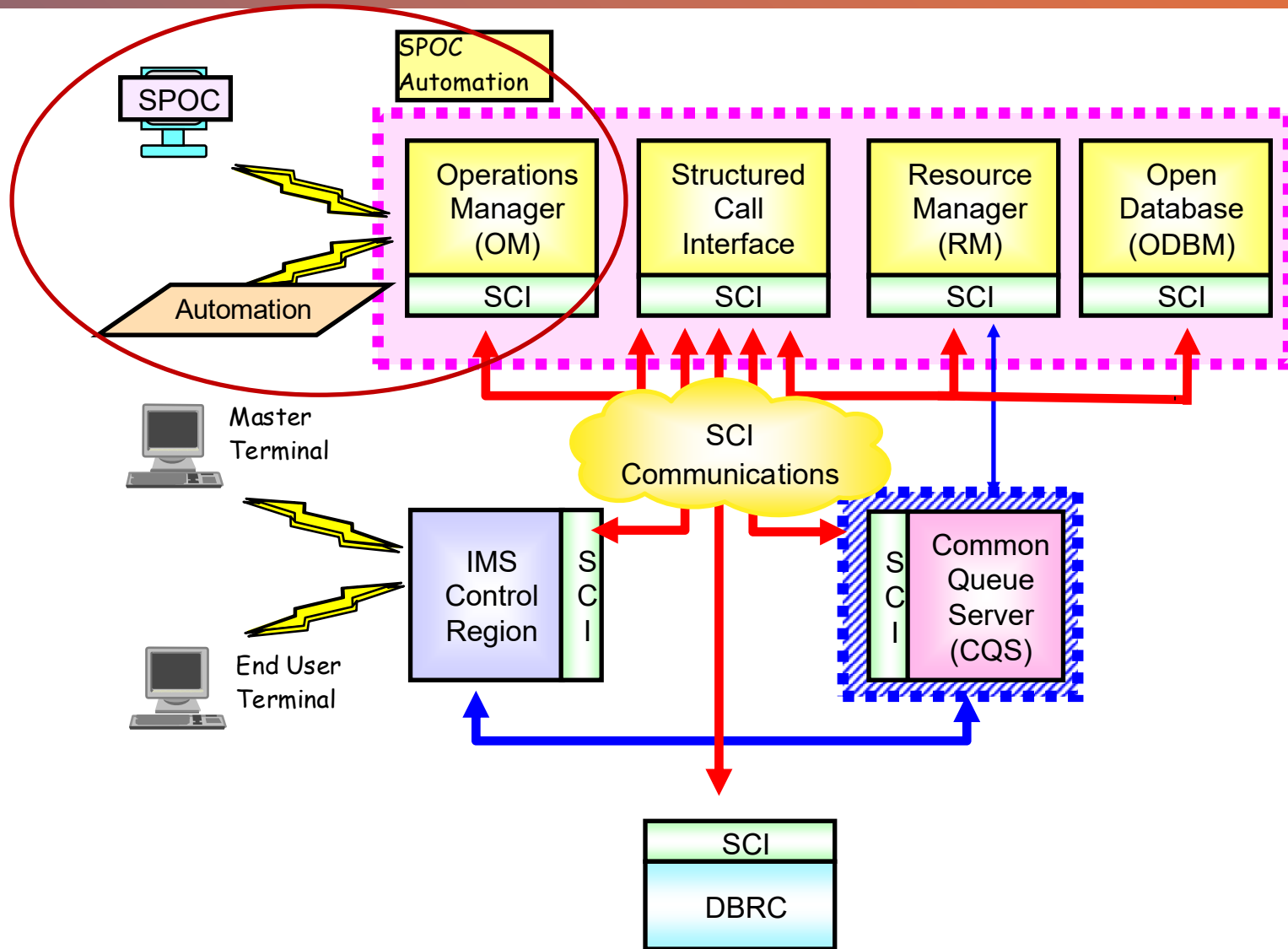

+

•

○

# Resource Manager Why?

- Provides infrastructure for managing global resources and IMSplex-wide processes
  - IMS is responsible for exploiting RM services
- Provides the following services
  - Maintains global resource information using a resource structure in a Coupling Facility
  - Coordinates IMSplex-wide processes
- Used for the following functions
  - Sysplex Terminal Management (STM)
  - Global Online Change (GOLC)
  - Global Callable Services
  - Global Status
  - Sysplex Serial Program Management (SSPM)
  - ACBLIB Member Online Change
  - Database Quiesce
  - IMS Repository – **Recommended!**

# Resource Manager Setup

- At least one RM address space is required in an IMSplex to use RM functions
  - Recommend a second RM for backup
  - If you do not require RM functions, you can configure without an RM by specifying RMENV=N in the CSL section of your DFSDFXxx PROCLIB member
- A resource structure is optional in an IMSplex
- RM started task JCL found in IMS.PROCLIB (CSLRM)
- Consolidate smaller bullet points Each RM address space
  - Executes BPEINI00
  - RM initialization module
    - BPEINIT=CSLRINI0
  - RM PROCLIB member
    - CSLRIxxx RMINIT=xxx
  - Each instance of RM has a different initialization PROCLIB member to specify its unique RM name (and IMSplex name)

# IMS Resource Manager – Started Task JCL

```
EDIT          SVTSC.PROCLIB(IMS15RM1) - 01.00          Columns 00001 00072
Command ==>                                         Scroll ==> CSR
000032 //IEFPROC EXEC PGM=BPEINI00,REGION=3000K,
000033 // PARM=( 'BPECFG=BPECONFIG', 'BPEINIT=CSLRINI0', 'RMINIT=000',
000034 //          'ARMRST=N', 'RMNAME=RM1' )
000035 //*
000036 //STEPLIB DD DSN=DFSF10.USER.SDFSRESL,DISP=SHR
000037 //          DD DSN=DFSF10.SDFSRESL,DISP=SHR
000038 //PROCLIB DD DSN=VENDOR.PROCLIB,DISP=SHR
000039 //          DD DSN=SVTSC.PROCLIB,DISP=SHR
000040 //          DD DSN=DFSF10.PROCLIB,DISP=SHR
000041 //*
000042 //SYSPRINT DD SYSOUT=*
000043 //SYSUDUMP DD SYSOUT=*
000044 //*
***** ***** Bottom of Data *****
```

# IMS Resource Manager – Infrastructure

```
EDIT          DFSF10.PROCLIB(CSLRI000) - 01.01          Columns 00001 00072
Command ==>                                         Scroll ==> CSR
***** ***** Top of Data *****
000001 *-----*
000002 * RM INITIALIZATION PROCLIB MEMBER.                *
000003 *-----*
000004 ARMRST=N,                                       /* SHOULD ARM RESTART RM ON FAILURE */
000005 RMNAME=RM1,                                     /* RM NAME (RMID = RM1RM)           */
000006 IMSPLEX(NAME=PLEX1)                            /* IMSPLEX NAME (CSLPLEX1)         */
000007 *-----*
000008 * REPOSITORY SECTION ADDED 10/01/24                 *
000009 *-----*
000010 <SECTION=REPOSITORY>
000011 * REPOSITORY=(NAME=RSRVNMRP,TYPE=IMSRSC,GROUP=REPXCFGN)
000012 REPOSITORY=(NAME=RSRVNM,TYPE=IMSRSC,GROUP=REPXCFGN)
000013 * AUDITACCESS=NOAUDIT | SECURITY | UPDATE | READ | SYSTEMREAD
000014 *-----*
000015 * END OF MEMBER CSLRI000                             *
000016 *-----*
***** ***** Bottom of Data *****
```

# CSL Architecture – Resource Manager (RM)

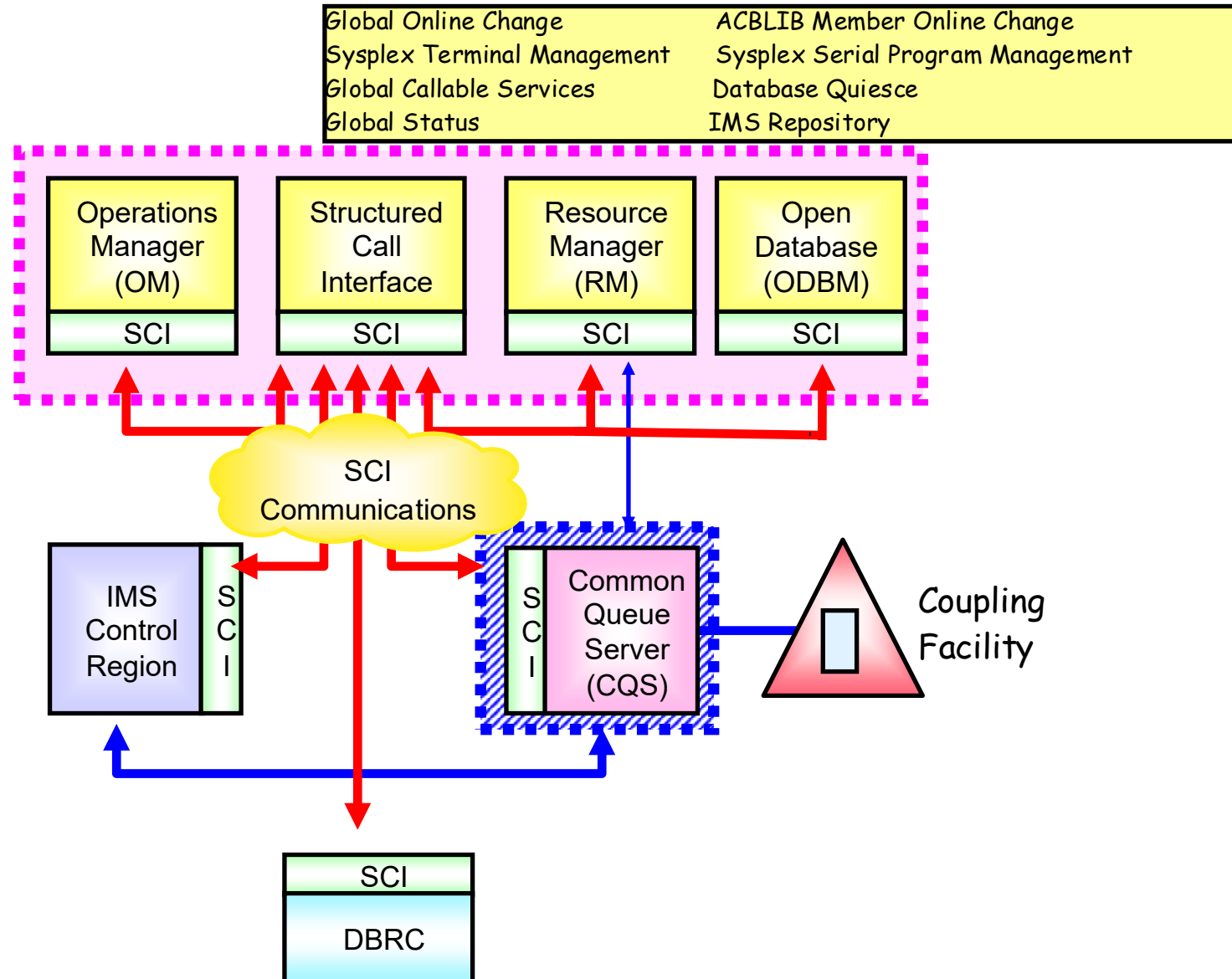

+

•

○

# Dynamic Resource Definition Why?

- Modify IMS Resources using Type 2 commands without IMS sysgen
  - IMS Transaction Manager Meta Data
    - Communications
    - Programs
    - Transactions
  - IMS Database Manager



# IMS Dynamic Resource Definition – Requirements

- Structure Call Interface
- Operations Manager
- Resource Manager
- Repository Server
- SPOC

# IMS Dynamic Resource Definition – Infrastructure (DRD)

```
EDIT          DFSF10.PROCLIB(DFSDF000) - 01.09          Columns 00001 00072
Command ==>          Scroll ==> CSR
000031 *-----*
000032 * DYNAMIC RESOURCES SECTION                               *
000033 *-----*
000034 <SECTION=DYNAMIC_RESOURCES>
000035 AUTOEXPORT=AUTO          /* AUTO EXPORT RESOURCES TO RDDS */
000036 AUTOIMPORT=AUTO         /* AUTO IMPORT RESOURCES FR RDDS */
000037 * UPDATED AUTOXXX VALUES TO REPO FROM AUTO             *
000038 * RDDSDSN=(                                               *
000039 * DFSF10.MODBLKSA.RDDS)                                   *
000040 * DFSF10.RDDS1,    NEW MODBLKSA RDDS ADDED ABOVE IS VSAM AS *
000041 * DFSF10.RDDS2,    SEQUENTIAL FORMATTING IS OUTDATED.     *
000042 * DFSF10.RDDS3)    ALTERED 10/01/24                       *
000043 *-----*
```

# IMS Dynamic Resource Definition – Infrastructure (DRD)

```
EDIT          DFSF10.PROCLIB(DFSDF000) - 01.09          Columns 00001 00072
Command ==>          Scroll ==> CSR
***** Top of Data *****
000001 *-----*
000002 * REPOSITORY SECTION - ADDED 10/01/24 *
000003 *-----*
000004 <SECTION=REPOSITORY>
000005 REPOSITORY=(TYPE=(IMSRSC))
000006 *-----*
```

+

•

○

# Open Database Manager Why?

- Supports open standards for distributed and local Java application program connectivity to IMS databases
- Provides the following services
  - IMS Universal Drivers
  - Works with IMS Connect using DRDA for distributed access (type-4 JDBC drivers)
  - Works through DRA (Database Resource Adapter) interface for local access within a z/OS LPAR or across z/OS LPARs (type-2 JDBC drivers)
- Used for the following functions
  - Open Database access
- One ODBM address space is required on each z/OS image that contains databases to which ODBM clients (such as the IMS Universal Drivers) require access per IMSplex

# Open Database Manager Setup

- One ODBM address space is required on each z/OS image that contains databases to which ODBM clients (such as the IMS Universal Drivers) require access per IMSplex
- ODBM started task JCL found in IMS.PROCLIB (CSLODBM)
- Each ODBM address space
  - Executes BPEINI00
  - ODBM initialization module
    - BPEINIT=CSLDINI0
  - ODBM PROCLIB member CSLDIxxx
    - ODBMINIT=xxx
  - Each instance of ODBM has a different initialization PROCLIB member to specify its unique ODBM name (and IMSplex name)

# IMS Open Database Manager – Started Task JCL

```
EDIT          SVTSC.PROCLIB(IMS150D1) - 01.00          Columns 00001 00072
Command ==>                                         Scroll ==> CSR
000003 //*****
000004 //IMS150D1  PROC BPECFG=BPEODBM,
000005 //          ODBMINIT=000,
000006 //          CSLDI=CSLDINI0,
000007 //          PARM1='RRS=Y,ARMRST=N'
000008 //*
000009 //ODBM      EXEC PGM=BPEINI00,REGION=0M,TIME=NOLIMIT,
000010 //  PARM='BPECFG=&BPECFG,BPEINIT=&CSLDI,ODBMINIT=&ODBMINIT,&PARM1'
000011 //STEPLIB  DD   DSN=DFSF10.SDFSRESL,DISP=SHR
000012 //          DD   DSN=SYS1.CSSLIB,DISP=SHR
000013 //PROCLIB   DD   DSN=DFSF10.PROCLIB,DISP=SHR
000014 //SYSPRINT DD   SYSOUT=X
000015 //SYSUDUMP DD   SYSOUT=X
000016 //CCTLSNAP DD   SYSOUT=X
***** ***** Bottom of Data *****
```

# IMS Open Database Manager – Infrastructure

```
EDIT          DFSF10.PROCLIB(CSLDI000) - 01.01          Columns 00001 00072
Command ==> _____ Scroll ==> CSR
000013 *****
000014 ODBMNAME=IVP1
000015 IMSPLEX(NAME=PLEX1)
000016 ODBMCFG=000
***** Bottom of Data *****
```

# IMS Open Database Manager – Infrastructure

```
EDIT          DFSF10.PROCLIB(CSLDC000) - 01.02          Columns 00001 00072
Command ==>           Scroll ==> CSR
000054 *****
000055 <SECTION=LOCAL_DATASTORE_CONFIGURATION>
000056 ODBM(NAME=IVP1
000057 DATASTORE(NAME=IVP1
000058 ALIAS(NAME=IVP1)
000059 MAXTHRDS=10
000060 MINTHRDS=3
000061 )
000062 )
***** Bottom of Data *****
```

# Open Database Manager Access - ODBM

- Implemented with Common Service Layer
- Allows database access outside of dependent region
  - IMS Universal Database resource adapter (DRDA)
  - Open Database Access interface (ODBA)
  - IMS Universal JDBC driver
  - IMS Universal DL/I driver
  - ODBM CSLDMI interface
- Security & Access through IMS Connect

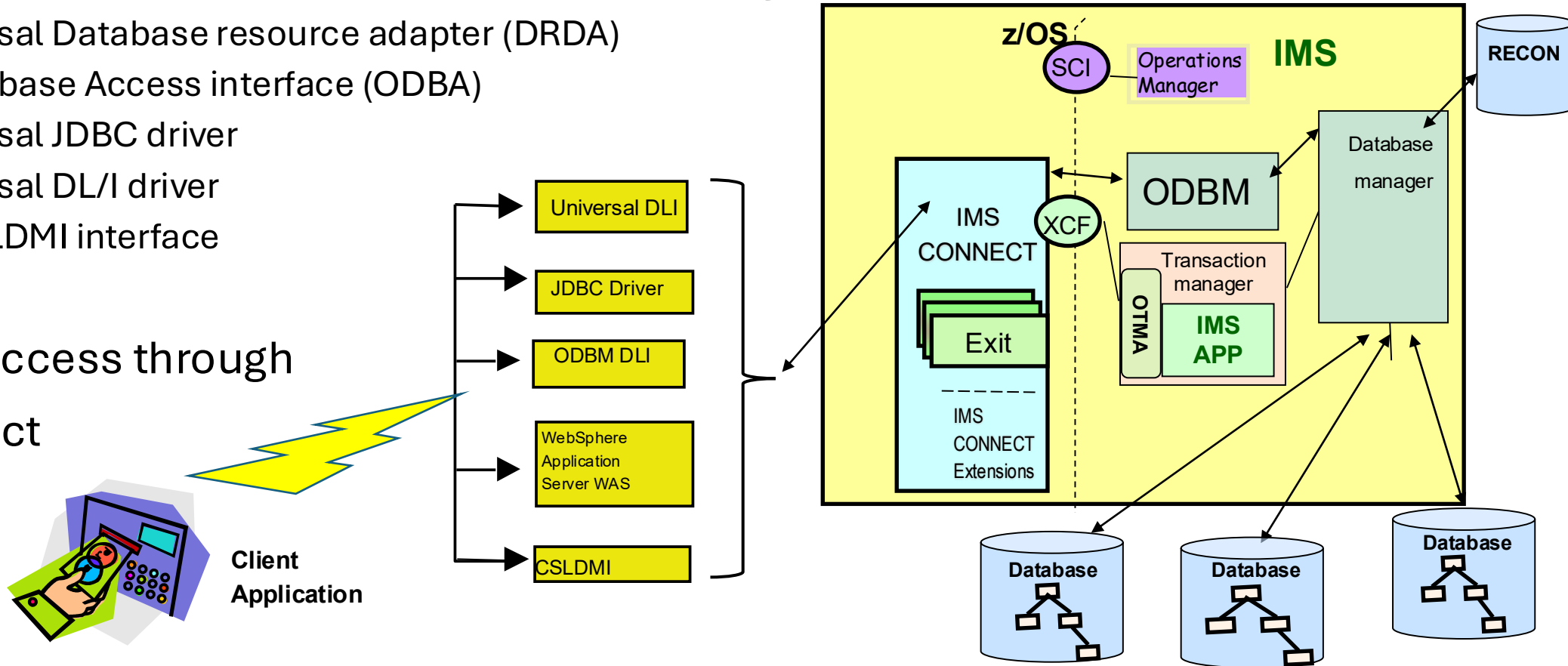

# IMS Common Service Layer – Infrastructure

```
EDIT          DFSF10.PROCLIB(DFSDF000) - 01.09          Columns 00001 00072
Command ==>          Scroll ==> CSR
000020 *-----*
000021 * COMMON SERVICE LAYER SECTION                      *
000022 *-----*
000023 <SECTION=COMMON_SERVICE_LAYER>
000024 CMDSEC=N                      /* NO CMD AUTHORIZATION CHECKING */
000025 IMSPLEX=PLEX1                  /* IMSPLEX NAME                    */
000026 MODBLKS=DYN                    /* DRD ENABLED;MODBLKS OLC DISABLE */
000027 OMPROC=IMS150M1                /* OPERATIONS MANAGER              */
000028 RMENV=Y                        /* RESOURCE MANAGER ENABLED         */
000029 RMPROC=IMS15RM1                 /* RESOURCE MANAGER PROC            */
000030 SCIPROC=IMS15SCI               /* SERVICE CALL INTERFACE           */
000031 *-----*
```

# Common Service Layer in Action!!!



Create resources (programs and transactions) in an instant via TSO SPOC!!!

Go to Option 6 for ISPF Command Shell, and enter..  
**EXEC 'imshlq.SDFSEXEC(DFSAPPL)' 'HLQ(imshlq)'**

```
Help
-----
                                IMS Application Menu
Command ==> █
-----
Select an application and press Enter.

1  Single Point of Control (SPOC)
2  Manage resources
3  Reserved for future use
4  HALDB Partition Definition Utility (PDU)
5  Syntax Checker for IMS parameters (SC)
6  Installation Verification Program (IVP)
7  IVP Export Utility (IVPEX)
8  IPCS with IMS Dump Formatter (IPCS)
9  Abend Search and Notification (ASN)

To exit the application, press F3.
```

And then select Option 1 for Single Point of Control (SPOC)

PLEX1 IMS Single Point of Control

Command ==>

Plex . . PLEX1 Route . . IVP1 Wait . .

Response for: CREATE PGM NAME(PGM00001) SET(BMPTYPE(Y))

PgmName	MbrName	CC
PGM00001	IVP1	0

# CREATE a new program

PLEX1

IMS Single Point of Control

Command ==> █

---

Plex . . PLEX1    Route . . IVP1    Wait . .

Response for: QUERY PGM NAME(PGM00001) SHOW(ALL)    More: >

PgmName	MbrName	CC	LRgnType	LBMPType	LFP	LDOPT	LGPSB	LRsdnt	LTranStat	LPgmLa
PGM00001	IVP1	0	BMP	Y	N	N	N	N	N	

# QUERY a new program

```

SDSF SYSLOG      3322.101 SOW1 SOW1 02/16/2026 2W          4,827  COLUMNS 52- 131
COMMAND INPUT ==> █
0090  IEE600I REPLY TO 05 IS:/DIS PGM PGM00001
0090  DFS000I      PROGRAM      TRAN      TYPE      IVP1
0090  DFS000I      PGM00001          BMP  NOTINIT  IVP1
0090  DFS000I      *26047/111504*  IVP1
0090  *06 DFS996I *IMS READY*  IVP1

```

```

PLEX1                      IMS Single Point of Control
Command ==> █
-----
Plex . . PLEX1  Route . . IVP1  Wait . .
Log for . . : DIS PGM PGM00001

IMSpdex . . . . . : PLEX1
Routing . . . . . : IVP1
Start time . . . . : 2026.051 13:30:59.71
Stop time . . . . . : 2026.051 13:30:59.71
Return code . . . . : 00000000
Reason code . . . . : 00000000
Reason text . . . . :
Command master . . : IVP1

MbrName  Messages
-----
IVP1     PROGRAM      TRAN      TYPE
IVP1     PGM00001          BMP  NOTINIT
IVP1     *26051/133059*

```

/DIS PGM (pgmname)

```
PLEX1                IMS Single Point of Control
Command ==> █
-----
Plex . . PLEX1  Route . . IVP1  Wait . .
Response for: CREATE TRAN NAME(TRN123) SET(PGM(PGM00001) CLASS...
Trancode MbrName      CC
TRN123   IVP1         0
```

# CREATE a new transaction

```

PLEX1                IMS Single Point of Control
Command ==> █
-----
Plex . . PLEX1  Route . . IVP1  Wait . .
Response for: QUERY TRAN NAME( TRN123) SHOW(ALL)  More: >
Trancode MbrName  CC LPSBname LCls  LQCnt  LLCT  LPLCT  LPLCTTime  LCPRI  LNPRI
TRN123   IVP1    0 PGM00001   3     0  65535  65535   6553500    0     0

```

# QUERY a new transaction

```

SDSF SYSLOG 3322.102 SOW1 SOW1 02/20/2026 2M 981 COLUMNS 52- 131
COMMAND INPUT ==>
0090 IEE600I REPLY TO 06 IS:/DIS TRAN TRN123
0090 DFS000I TRAN CLS ENQCT QCT LCT PLCT CP NP LP SEGSZ SEGNO
PARLM RC IVP1
0090 DFS000I TRN123 3 0 0 65535 65535 0 0 0 0 0
NONE 0 IVP1
0090 DFS000I PSBNAME: PGM00001 IVP1
0090 DFS000I *26051/134712* IVP1
0090 *07 DFS996I *IMS READY* IVP1

```

```

IMS Single Point of Control
Command ==>
-----
Plex . . PLEX1 Route . . IVP1 Wait . .
Log for . . : DIS TRAN TRN123 More: >
IMSpdex . . . . . : PLEX1
Routing . . . . . : IVP1
Start time . . . . : 2026.051 13:36:55.57
Stop time . . . . . : 2026.051 13:36:55.57
Return code . . . . : 00000000
Reason code . . . . : 00000000
Reason text . . . . :
Command master . . : IVP1
MbrName Messages
-----
IVP1 TRAN CLS ENQCT QCT LCT PLCT CP NP LP SEGSZ SEGNO PARLM
IVP1 TRN123 3 0 0 65535 65535 0 0 0 0 0 NONE
IVP1 PSBNAME: PGM00001
IVP1 *26051/133655*

```

/DIS TRAN (tranname)



# In Conclusion...

- Common Service Layer is part of the evolving IMSplex architecture
- Required to take advantage of many new IMS functions
- Improvements for Operations Management
- Improvements for Resource Management
- Improvements for IMS Database access
- Begin implementing CSL now under your current IMS version so you can exploit many new IMS functions now as well as when you migrate to new versions



Questions?

+  
•  
○

Thank you!!!

# Your feedback is important!

Submit a session evaluation for each session you attend:

[www.share.org/evaluation](http://www.share.org/evaluation)



# Want to attend an in-person IBM z/OS Academy?



**Learn, Interact** and **Network** with IBMers and peers

**May 5<sup>th</sup>- 7<sup>th</sup>, 2026**

**Fall 2026**

**IBM Tech Campus**

**IBM US**

**Ehningen, Germany**

**New York, USA**

These **free** events are designed for early tenure z/OS system programmers (2-10 years), but all are welcome!

Training and presentations include topics on new z/OS capabilities, best practices, career tips, and **much more!**

Subscribe to the community page today to stay informed about future events!

*Register now  
for Ehningen/  
Germany:*



Join our IBM Community: <https://ibm.biz/zOSAcademy>  
Questions? Contact us at [zOS.Academy.USA@us.ibm.com](mailto:zOS.Academy.USA@us.ibm.com) or  
[zOS.Academy.Europe@de.ibm.com](mailto:zOS.Academy.Europe@de.ibm.com)

# Experience more with IBM



## Visit us at the IBM Booth #113

After a full day of technical sessions, take a break with us!

Connect with our experts, snap a photo with the z17 Plexi or the latest Telum II, and get an up-close look at our Spyre Accelerator.

Come back each day for fresh topics and demos at our expert stations.

## Think 2026

Join 5000+ senior business and technology leaders who are seizing the AI revolution to unlock unprecedented growth and productivity at **Think 2026**.

Find out more information using the QR code below.



## IBM Digital Asset Haven

IBM Digital Asset Haven is the operational backbone for financial institutions and regulated enterprises entering the digital asset economy.

Find out more information using the QR code below.



# Appendix:

- <https://www.ibm.com/docs/en/ims/15.6.0?topic=overview-csl-configuration-examples>
- <https://www.ibm.com/docs/en/ims/15.6.0?topic=cdt-defining-common-service-layer-using-ims-proclib-data-set-members>
- <http://ibm.com/docs/en/ims/15.5.0?topic=tailoring-sequence-starting-csl-address-spaces>
- <https://www.ibm.com/docs/en/ims/15.6.0?topic=overview-defining-tailoring-imsplex>
- <https://www.ibm.com/docs/en/ims/15.6.0?topic=ims-controlling-tso-spoc-application>
- <https://www.ibm.com/docs/en/ims/15.6.0?topic=administrator-base-primitive-environment-overview>
- <https://www.ibm.com/docs/en/ims/15.6.0?topic=overview-ims-type-2-command-format>
- <https://www.ibm.com/docs/en/ims/15.6.0?topic=overview-equivalent-ims-type-1-type-2-commands>
- <https://www.ibm.com/docs/en/ims/15.6.0?topic=overview-defining-tailoring-imsplex>