

# z/VM Virtual Switch

21<sup>st</sup> Edition

Alan Altmark

Senior z/VM Engineer and Consultant  
IBM Infrastructure

[Alan\\_Altmark@us.ibm.com](mailto:Alan_Altmark@us.ibm.com)

## Notes

References to IBM products, programs, or services do not imply that IBM intends to make these available in all countries in which IBM operates. Any reference to an IBM product, program, or service is not intended to state or imply that only IBM's product, program, or service may be used. Any functionally equivalent product, program, or service that does not infringe on any of the intellectual property rights of IBM may be used instead. The evaluation and verification of operation in conjunction with other products, except those expressly designed by IBM, are the responsibility of the user.

IBM, the IBM logo, and ibm.com are trademarks or registered trademarks of International Business Machines Corp., registered in many jurisdictions worldwide. Other product and service names might be trademarks of IBM or other companies. A current list of IBM trademarks is available on the Web at "Copyright and trademark information" at [www.ibm.com/legal/copytrade.shtml](http://www.ibm.com/legal/copytrade.shtml).

# Topics

- Overview
- The Uplink
- The virtual NIC
- The VSWITCH controller
- Link Aggregation
- Port sharing
  - Global VSWITCH and shared port groups
- HiperSocket VSWITCH Bridge
- Diagnostics

# Multi-zone Network on IBM zSystems With outboard firewall / router

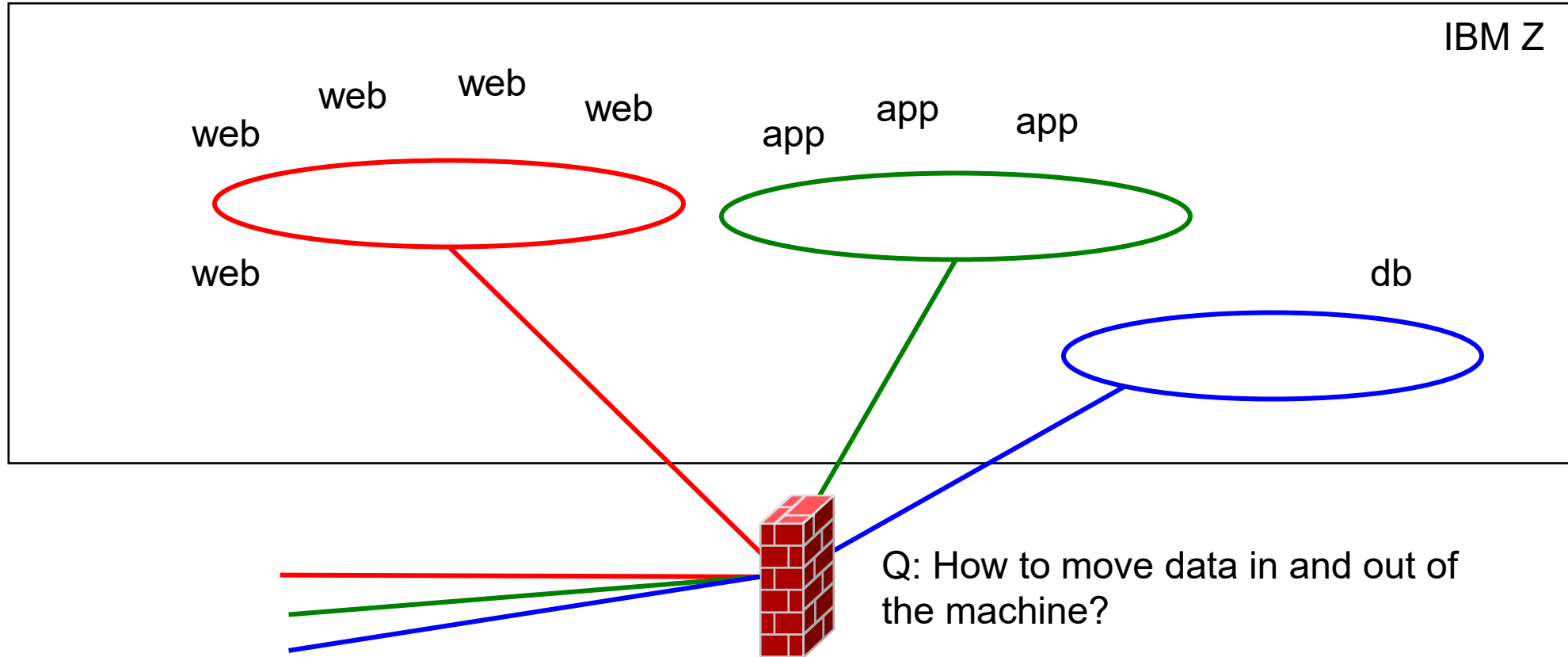

Q: How to move data in and out of the machine?

A: z/VM<sup>®</sup> Virtual Switch

## Q: What's a switch?

A: A network device management endpoint

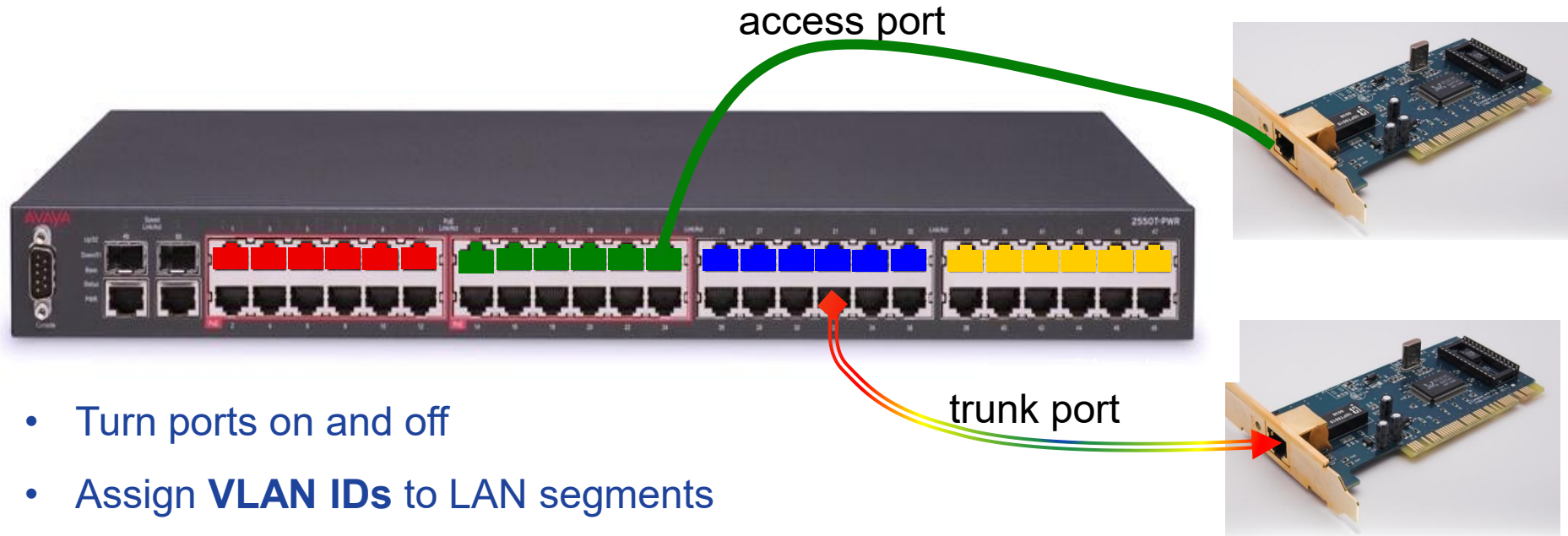

- Turn ports on and off
- Assign **VLAN IDs** to LAN segments
- Associate **access** ports with a single VLAN ID
- Associate **trunk** ports with multiple VLAN IDs
- Provide fast switching of data between ports
- Provide sniffer functions

## Q. What's a Bridge?

A: A way to connect two switches

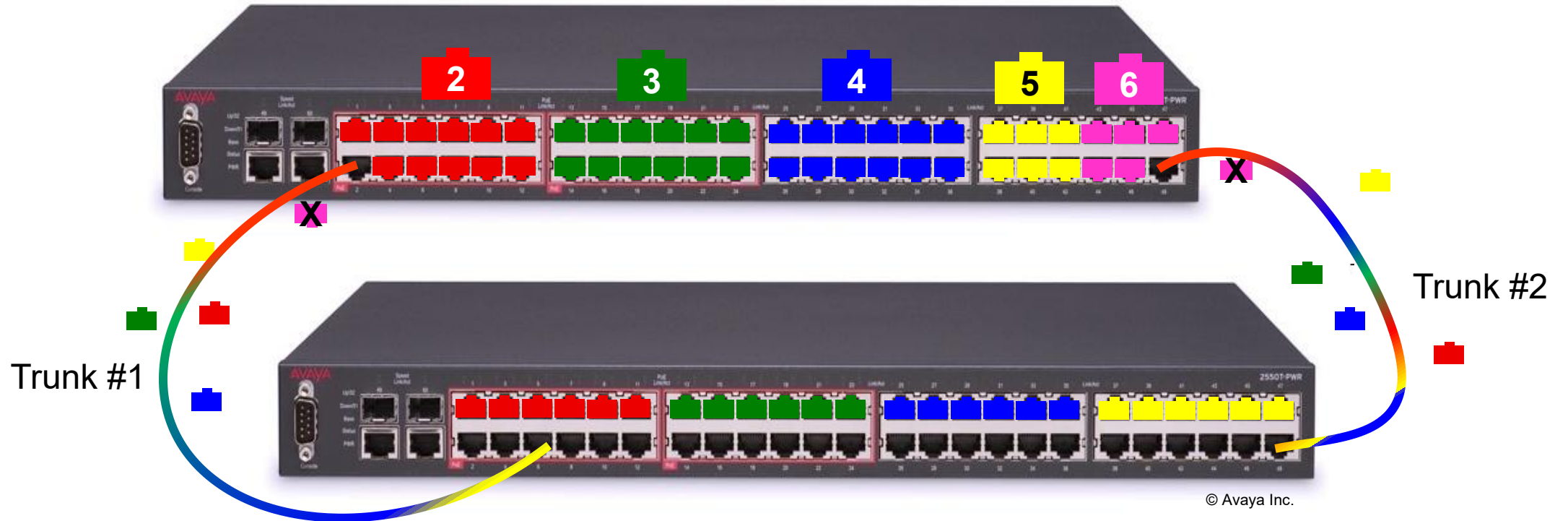

- If you run out of ports, you don't throw it away, you **bridge** it to an adjacent switch
- A **trunk** port carries ethernet frames for **multiple** LAN segments (subnets)
- **VLAN tags** in each frame identify the LAN segment it belongs to
- Redundant connections for high availability

# Bridge versus Router

- A bridge connects two LAN segments that are in the same subnet
  - aka "Layer 2 switch"
  - Behaves as a single LAN segment
  - Do not confuse this with deprecated term "Layer 2 VSWITCH"
- A router connects two LAN segments that are in different subnets
  - aka "Layer 3 switch"
  - Do not confuse this with deprecated term "Layer 3 VSWITCH"
- A VSWITCH configurations are **bridges**, not routers.

# VLAN-aware Virtual Switch

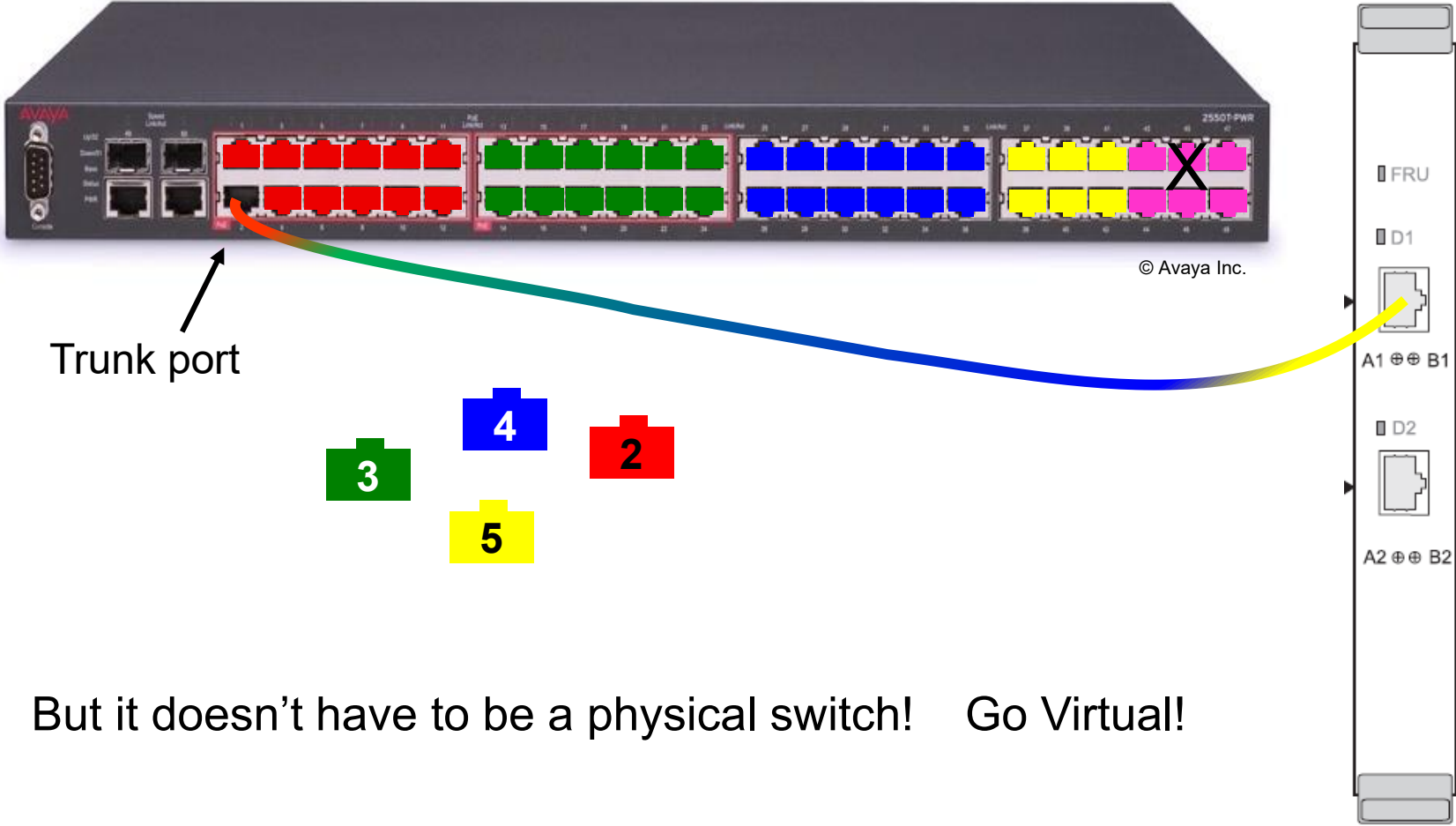

# The Virtual Switch

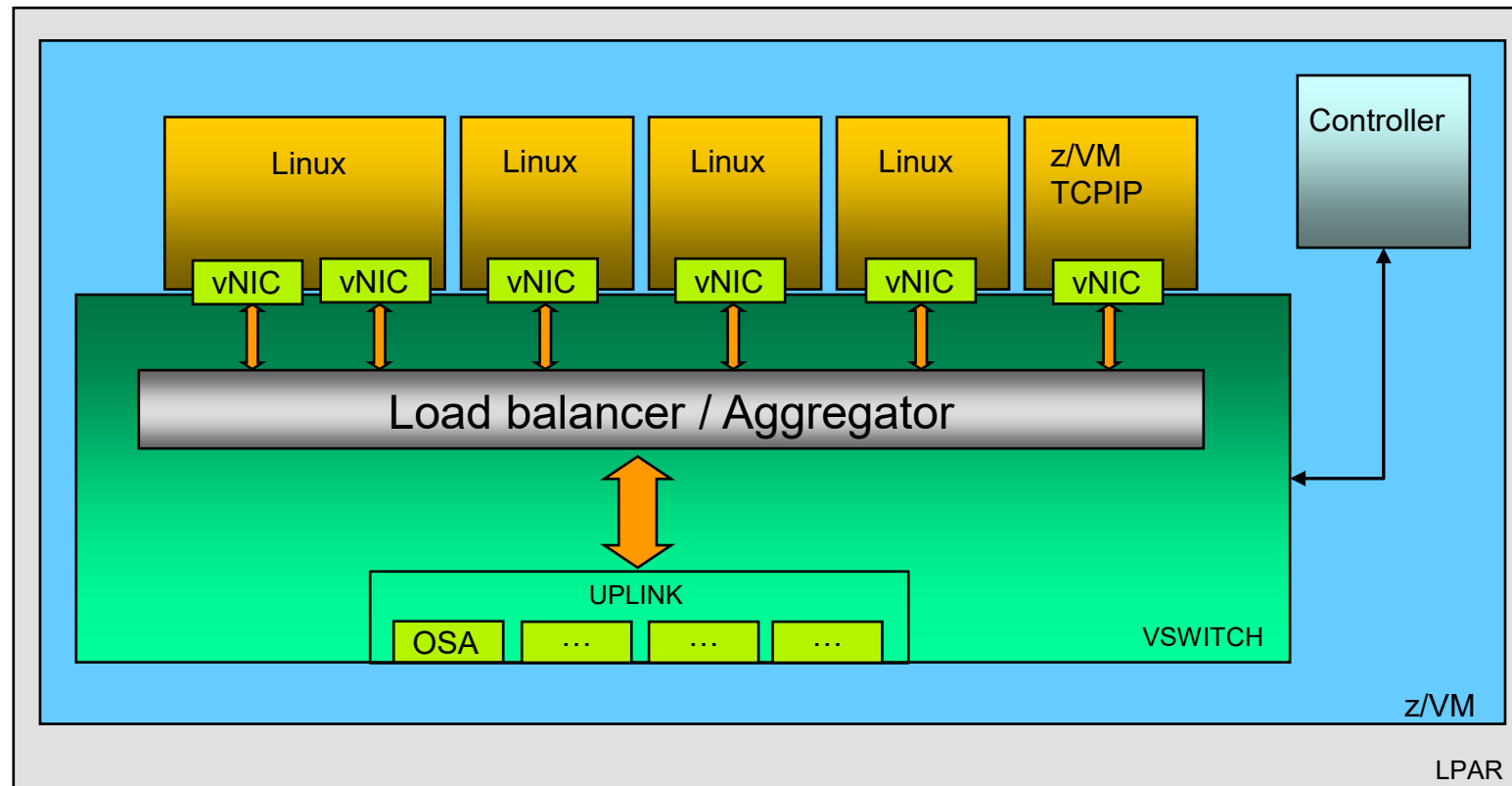

# The Virtual Switch

## Configurable Elements

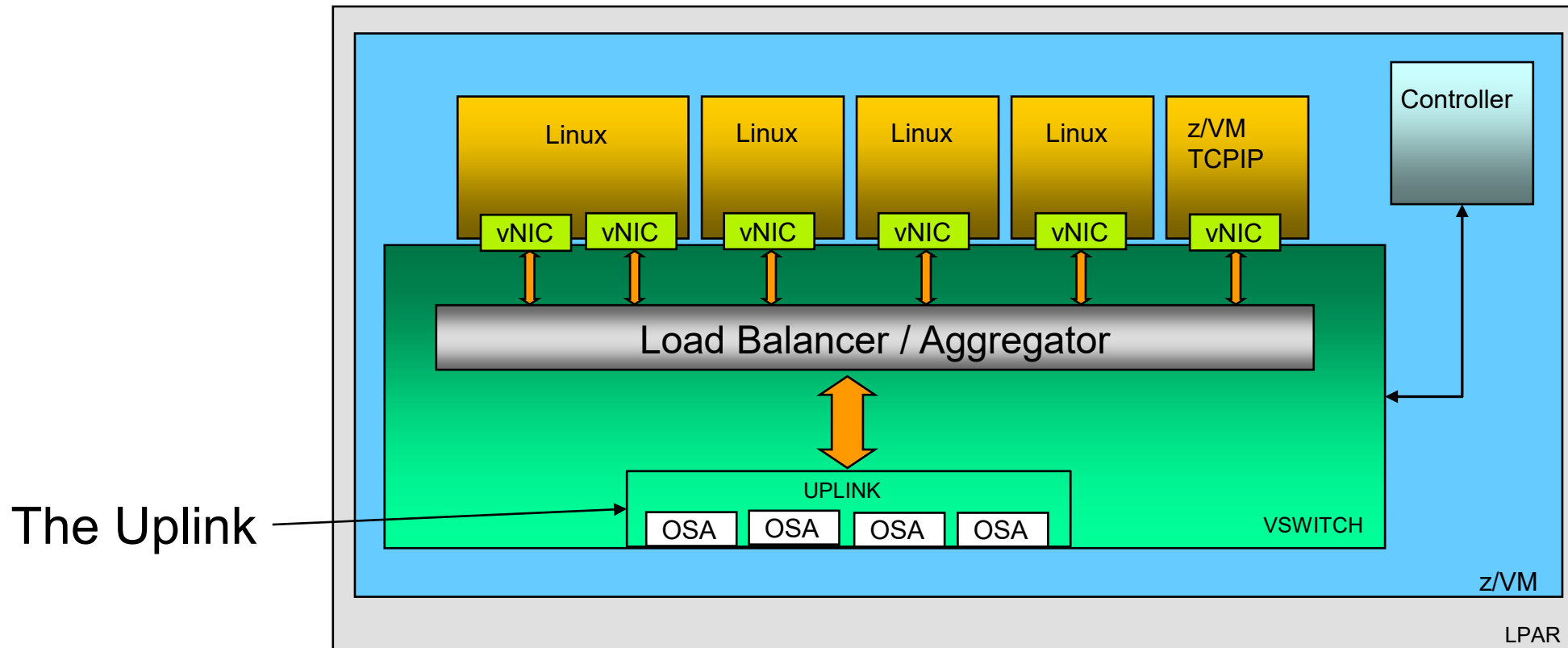

# The Virtual Switch

## Configurable Elements

The virtual network interfaces

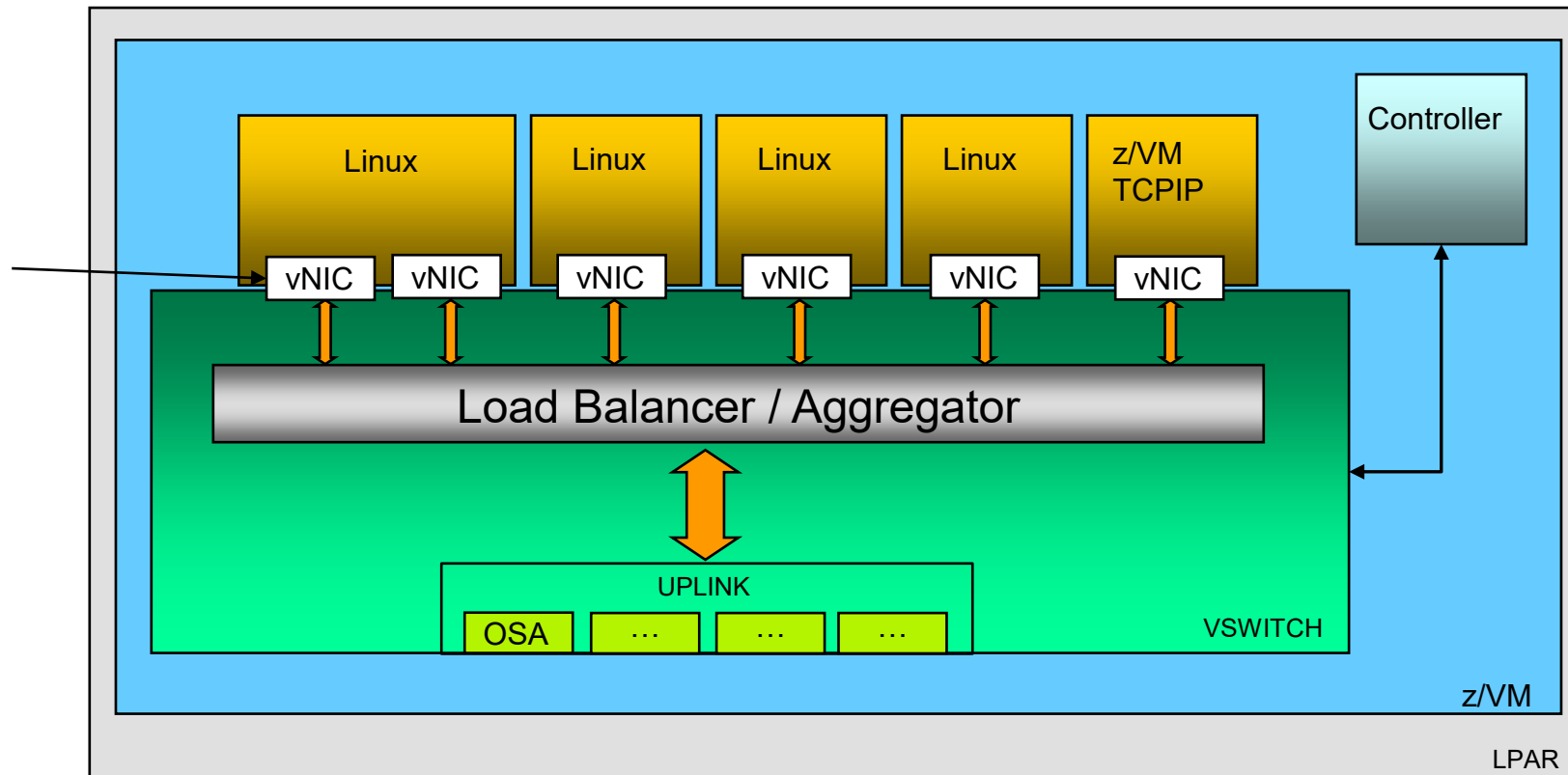

# The Virtual Switch

## Configurable Elements

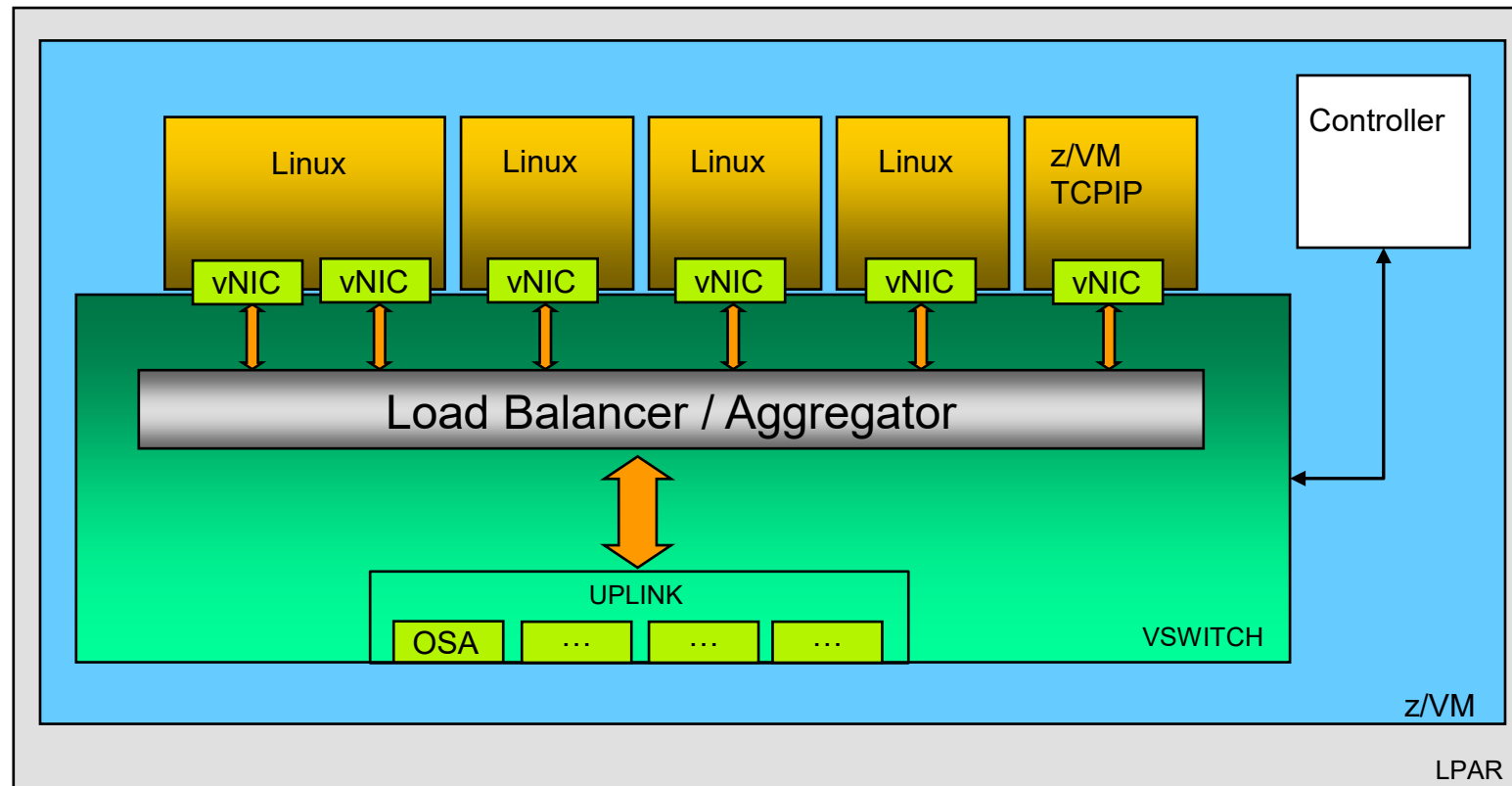

The  
Controller

# Virtual Switch general principles

— Bring controllers up first

- Used only for OSD chpids, not OSH

— `DEFINE VSWITCH name {ETHERNET | IP} PORTBASED`

```
    {uplink attributes}  
    {virtual NIC defaults}  
    {accounting settings}
```

— Unless otherwise configured, traffic remains as close to the virtual machines as possible

- Within the VSWITCH
- Within the OSA
- Out to the physical switch

## Suggested Practice:

- Use PORTBASED option for consistency of QUERY VSWITCH output and future directions
- Bring up in AUTOLOG1 / 2 after the controllers are up

# The Uplink

# Uplink Port

— Connects VSWITCH to network

- Without an uplink, data can move only among coupled guests
  - Better than a Guest LAN!

— OSA (OSD) or Network Express (OSH) CHPID

- OSA operates in ETHERNET or IP mode
- Network Express is ETHERNET only

— VLAN aware or unaware

— For high availability, you need more than one physical connection

- Single-port failover (serial)
- Link Aggregation port group (parallel)

## Uplink: IP mode

— DEFINE VSWITCH *name* IP PORTBASED  
[NONROUTER | PRIROUTER]

- Guest and host device driver sends and receives IP packets
- All virtual NICs have the same physical MAC address
  - Packet delivery based on guest-registered IP address
- Good for z/OS guests without support for IBM z17
  - No IPv6
  - No link aggregation



**Deprecated**

## Uplink: **ETHERNET** mode

— `DEFINE VSWITCH name ETHERNET PORTBASED`

— Guest and host device driver sends and receives fully-formed ethernet frames

— Virtual MAC address used as physical MAC address

- More about that later

# Uplink: port options

## — No ports

- Similar to Guest LAN, but with better security
- Excellent for 2nd level systems

## — One active port with one or two failover ports

- Round-robin failover
- If all dead, wait for signs of life
- SET VSWITCH SWITCHOVER to manually change
- Maximum bandwidth = 25 Gb/s

## — Up to 8 active ports operating concurrently

- IEEE 802.1AX link aggregation (a form of channel bonding)
- Maximum bandwidth = 200 Gb/s (8 x 25 Gb/s)
- SET PORT GROUP to add or remove ports
- ETHERNET mode only

## Uplink: Port selection

```
DEFINE VSWITCH ...  
  
    RDEV NONE  
or  
    RDEV port1 [port2 [port3] ]  
or  
    GROUP group_name
```

- RDEV NONE is a ***disconnected*** VSWITCH
- **Port** is identified by device number associated with an OSA or Network Express CHPID, plus and an optional physical port specification (P0 or P1)
  - 1EC0 (default is P0)
  - 1EC0.P0
  - 1EC0.P1
- Group name comes from **SET PORT GROUP**

# Uplink: Access port, VLAN unaware

VSWITCH carries traffic for a single LAN segment (subnet)

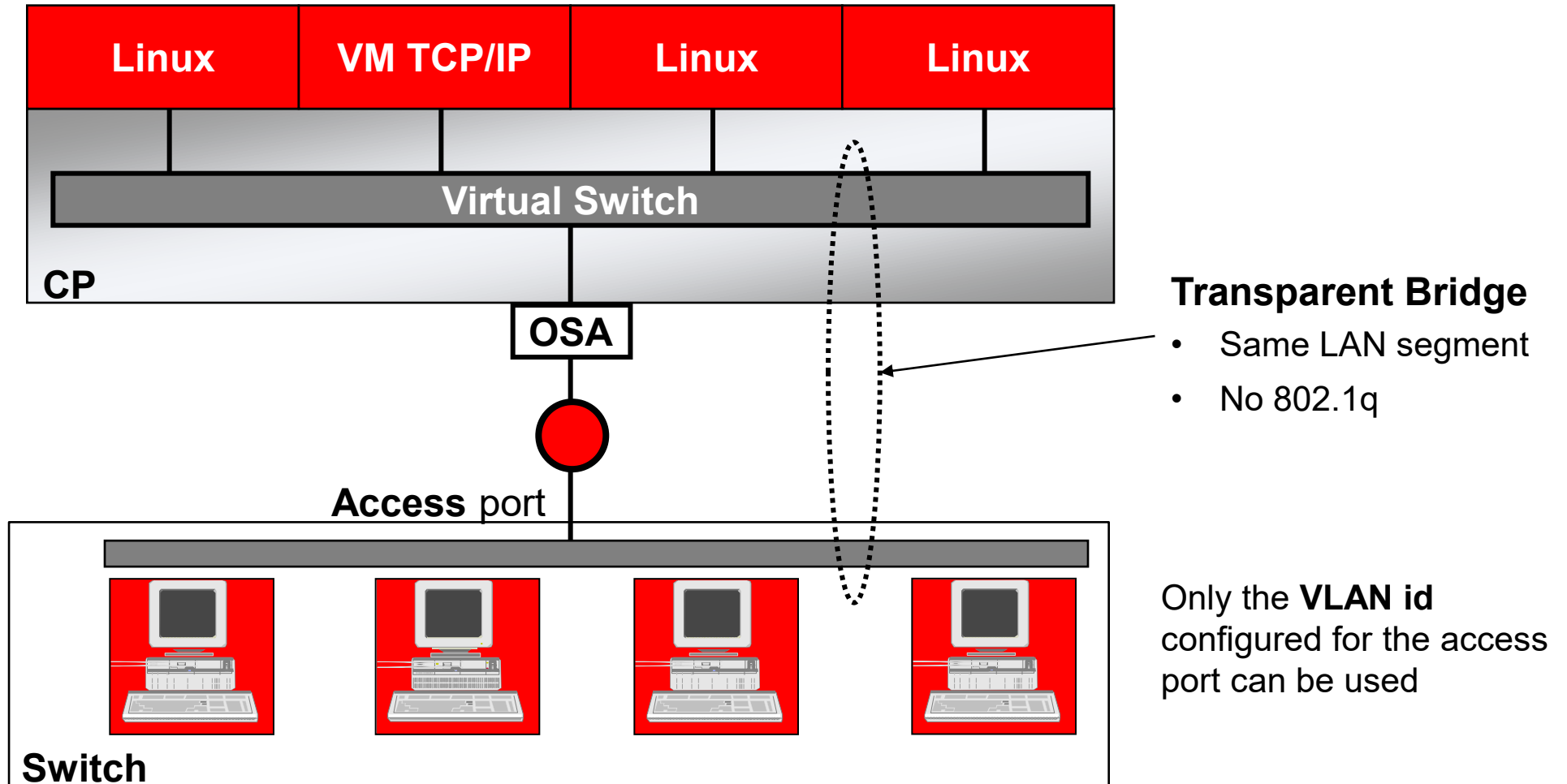

# Uplink: Trunk port, VLAN aware

VSWITCH carries traffic for multiple LAN segments (subnets)

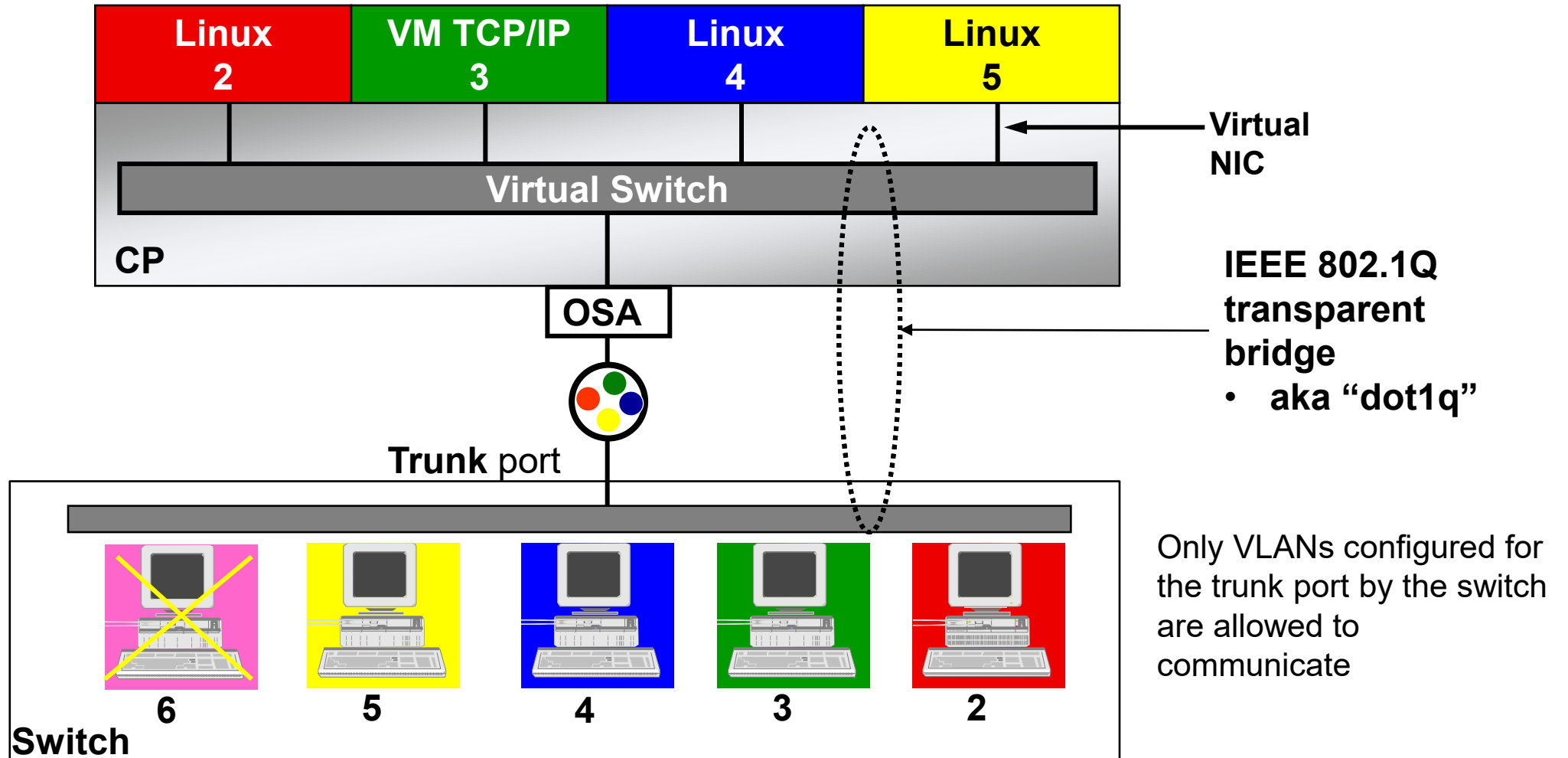

# VLAN-aware Virtual Switch

## Multiple LAN segments per VSWITCH

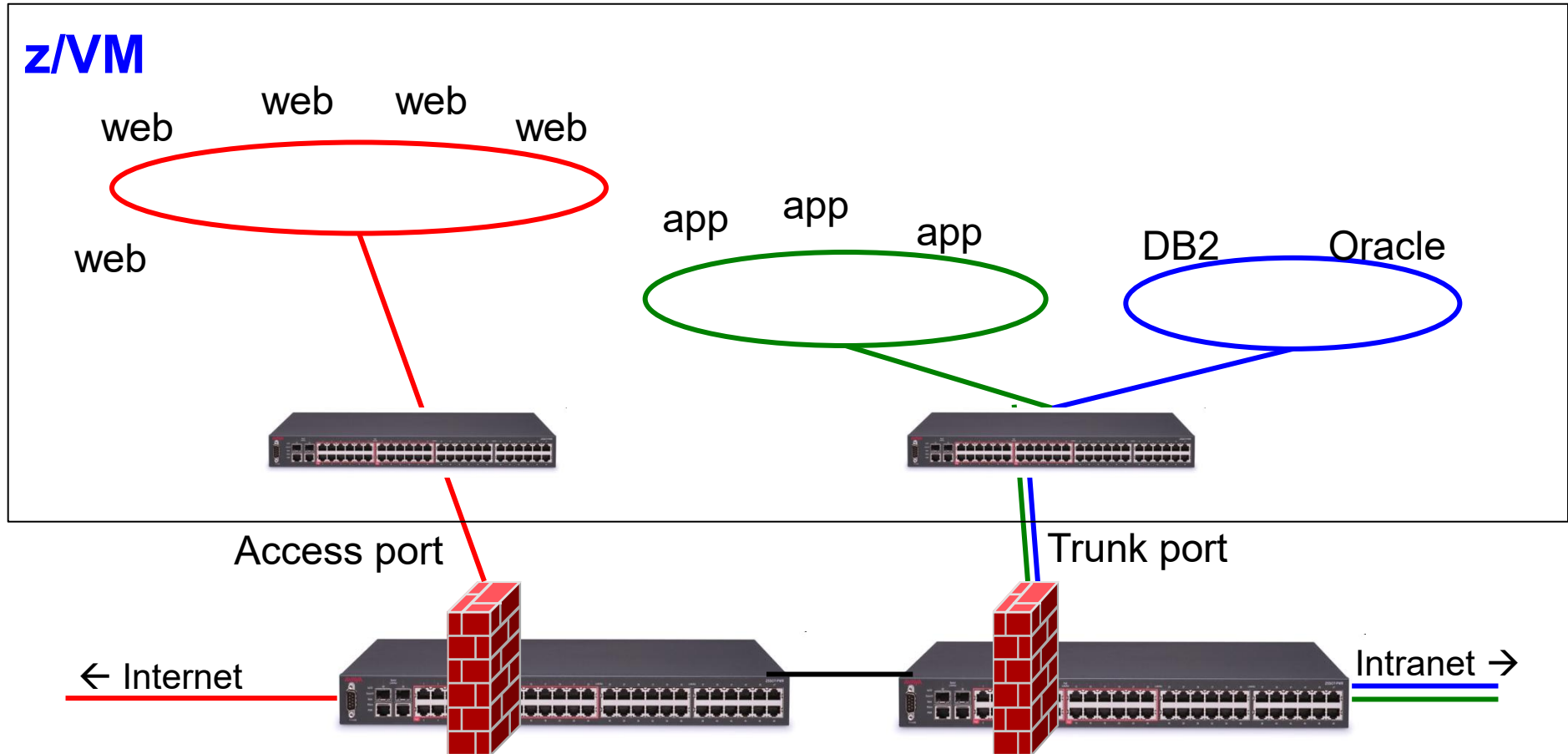

Shared infrastructure is cheaper than dedicated, but be aware of any rules that prohibit comingling of **Internet** and **Intranet** traffic on the same infrastructure

# Uplink: Trunk or Access port?

## — Access port

```
DEFINE VSWITCH ...  
    VLAN UNAWARE
```

- This is the default configuration

## — Trunk port

```
DEFINE VSWITCH ...  
    VLAN AWARE | vid  
    NATIVE 1 | NATIVE vid | NATIVE NONE
```

### Suggested Practices

- Use a trunk port defined using “VLAN AWARE NATIVE NONE”
- Don't specify PORTTYPE TRUNK (it doesn't do what you think it does)



## Sidebar: A word of advice about the native VLAN

- When an untagged frame is received on a trunk port the switch will associate the frame with the local default or native VLAN ID (VID), typically VLAN 1
- Used for switch management traffic
  - **Do not allow guests to interfere with the physical switch!**
- Identified by the NATIVE keyword on the DEFINE VSWITCH command
  - CP removes tags for frames associated with the native VLAN ID
- **VLAN nn NATIVE nn** is **wrong!**
  - Same number on both operands
  - You're really plugged into an **access port**
  - Change to VLAN UNAWARE
  - If any NICDEF has an assigned VLAN id that matches NATIVE nn, it's wrong, too!

### Suggested Practice

- Don't do wrong things!

# Disable class G user's ability to create a Guest LAN

— VMLAN statement in SYSTEM CONFIG:

```
VMLAN  
LIMIT TRANSIENT 0
```

## Suggested Practice

- Don't use Guest LANs – use a disconnected VSWITCH instead

# The Virtual NIC

# Virtual NIC

## Suggested Practice

- Do not use a virtual trunk port

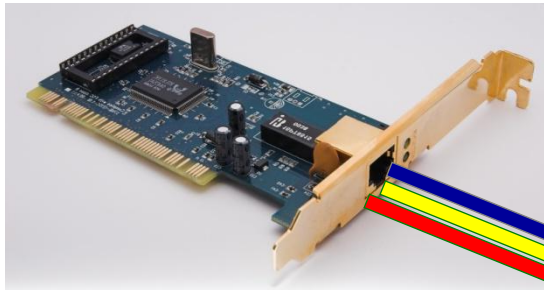

## Virtual trunk port

- More than one VLAN per NIC
- Requires more processing by the guest

## Virtual access port

- One VLAN per NIC

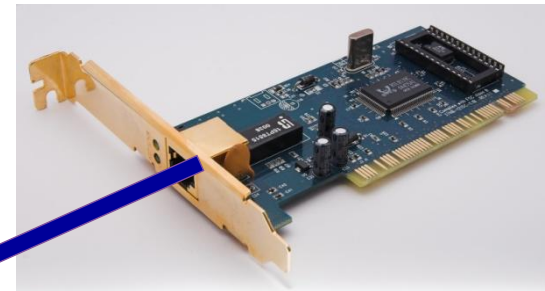
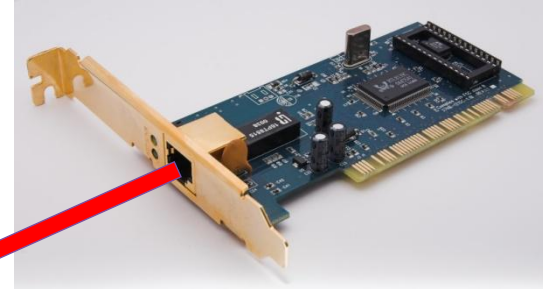

- A guest can have multiple virtual NICs, each on a different VLAN
- Same VSWITCH with different VLANs
- Different VSWITCH

# Virtual NIC: User Directory

Interface is fully configured in the user's directory entry

QDIO = virtual OSD  
EQDIO = virtual OSH



```
NICDEF vdev TYPE QDIO | EQDIO
LAN SYSTEM vswitch-name
[MACID hhhhhh]
[VLAN vlanid]
[PROMISCUOUS]
[PQUPLINKTX LOW | NORMAL | HIGH]

Example:
NICDEF 1100 TYPE QDIO LAN SYSTEM SWITCH1
NICDEF 1100 MACID B10006
NICDEF 1100 VLAN 57 PQUPLINKTX HIGH
```

Combined with VMLAN  
**USERPREFIX** to create virtual MAC

For VLAN-aware VSWITCH, the  
VLAN ID of this interface

Permission to sniff assigned VLANs

Transmission priority on the uplink

Specify NICDEF with same *vdev*  
to continue

Automatically creates *vdev*, *vdev*+1, and *vdev*+2

# Virtual NIC: MAC Addresses

## — 6 bytes

- E.g. 02:00:0A:00:01:23
- Prefix + ID

## — Prefix

- E.g. 02:00:0A
- Comes from **VMLAN** statement in SYSTEM CONFIG
  - Leading '02' is required; indicates that they are administratively-defined addresses, not globally unique

## — ID

- E.g. 00:01:23
- Persistent: From **MACID** operand of NICDEF directory entry
- Ephemeral: If not defined, set by CP

## — MAC will appear on the physical network

- ETHERNET mode VSWITCH only

# Virtual NIC: Controlling the MAC address

— Global attributes in the **VMLAN** statement in SYSTEM CONFIG:

```
VMLAN MACPROTECT ON
```

```
VMLAN MACPREFIX 02pppp
```

```
VMLAN USERPREFIX 02uuuu
```

Each item is prefixed with "VMLAN"

For CP-generated ephemeral MACs

For admin-assigned persistent MACs

## Suggested Practices

- MACPROTECT ON prevents guests from changing their assigned MAC address
- MACPREFIX unique per z/VM instance
  - Do not allow to default to 020000 (that's how you can detect a misconfigured system!)
  - Enforced for SSI
- USERPREFIX same across all members of a shared directory cluster
  - Enforced for SSI

# Virtual NIC: Sniffers

## — **Promiscuous** mode for sniffers

- Guest must be authorized via NICDEF
- Guest enables promiscuous mode using CP SET NIC or via device driver controls
  - E.g. tcpdump -P and download for Wireshark
- Guest receives copies of all frames sent or received for all authorized VLANs

# Virtual NIC: Priority Queuing

- **Priority Queuing** enables the host to provide an ordered set of outbound data queues that the adapter will service in order, but without queue starvation.
- CP creates four queues (in priority order):
  - System
  - High (guest)
  - Normal (guest)
  - Low (guest)
- You assign priority to each virtual NIC
  - Default is “normal”
- Activation required

```
DEFINE VSWITCH ...  
                PRIQUEUING ON
```

# z/VM with IBM z17 support

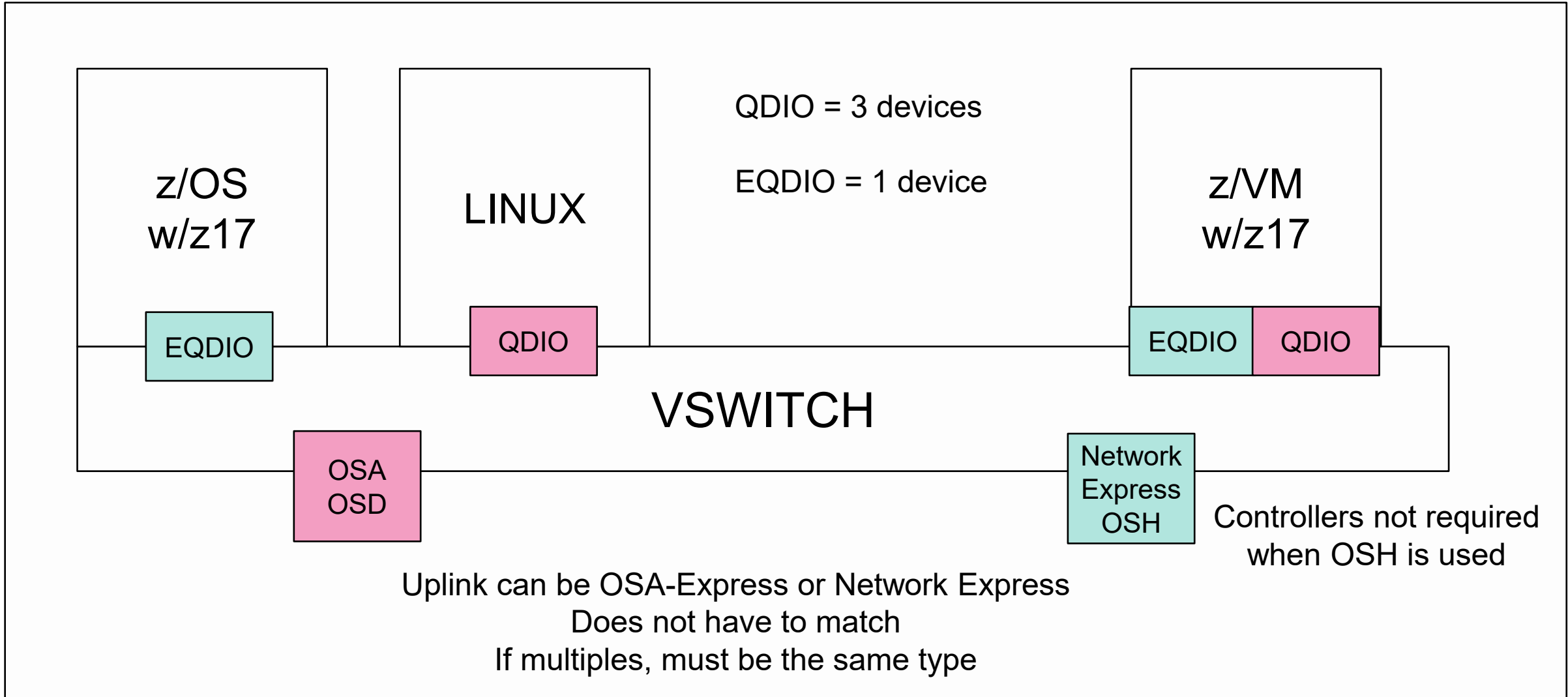

# The Controller

For OSA Express adapters

# VSWITCH Controller

- Virtual machine that handles OSA housekeeping duties
  - Specialized VM TCP/IP stack to start, stop, monitor, and query OSA
  - Each controller can service any number of VSWITCHes
  - Not involved in data transfer
  - **Not used for Network Express**
  
- DTCVSW1-DTCVSW4
  - Except for obey list, do not modify their configurations unless directed by Support Center
  - Monitor with system automation and keep them logged on
  - Automatic failover
  - If no controllers are available, uplink will stop!
    - Guest-guest communication ok
  
- Issues messages to virtual console during error recovery
  - NETSTAT CP CLOSE CONS TO *userid* (TCP DTCVSWn

# **IEEE 802.1AX Link Aggregation**

# Link Aggregation

Non-disruptive scalability and failover

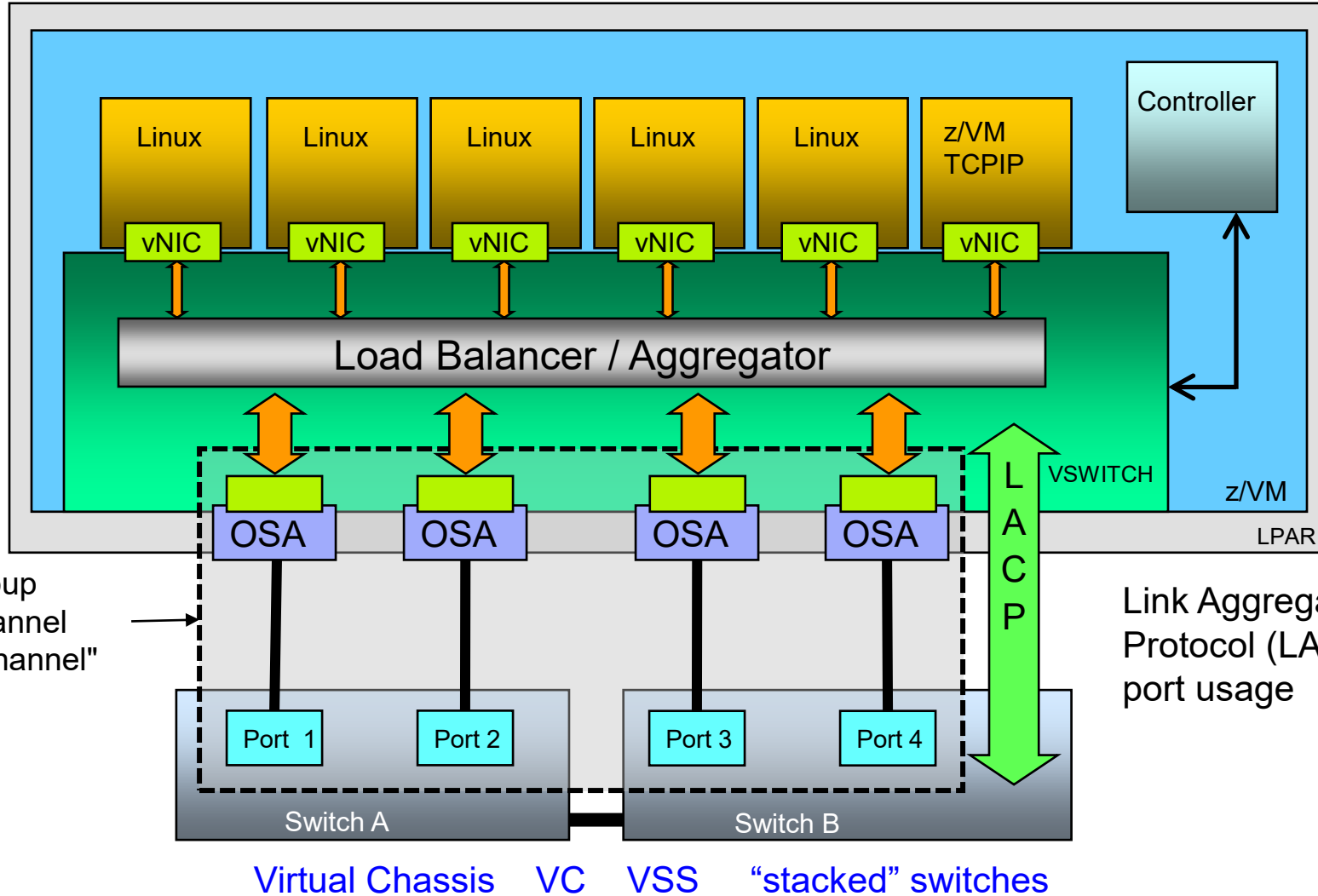

Virtual NIC assigned to a real NIC

VSWITCH or switch can initiate a change in the assignment via LACP.

- Port group
- Port channel
- "Etherchannel"

Link Aggregation Control Protocol (LACP) controls port usage

Virtual Chassis VC VSS "stacked" switches

# Failover (non-Link Aggregation)

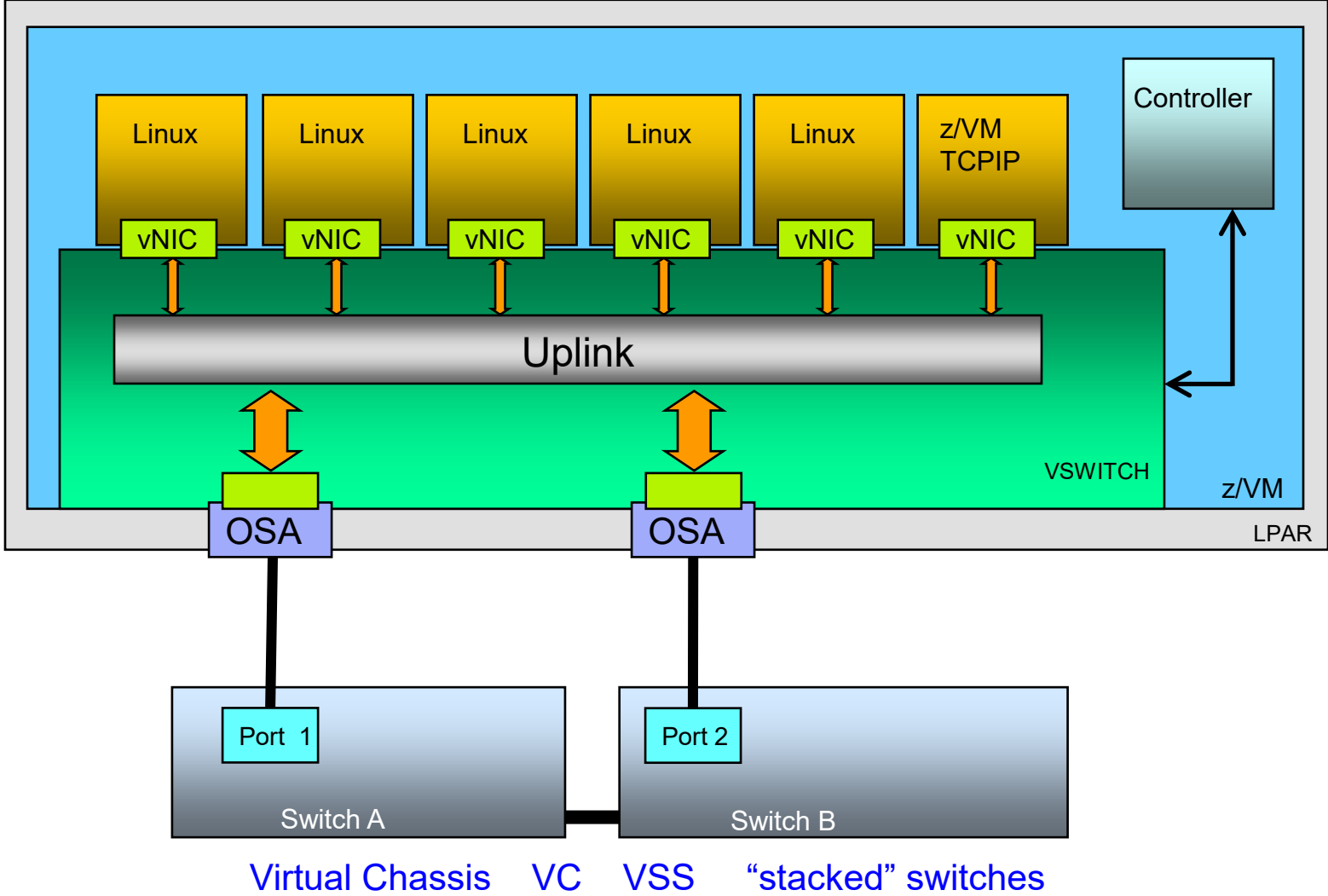

# Link Aggregation

- Binds multiple ports into a single pipe
  - Up to 8 OSA ports per virtual switch
  - Increases Virtual Switch bandwidth
  - Provides seamless failover in the event of a failed adapter, switch port, cable, or switch
  - Only supported for ETHERNET VSWITCHes
  - Virtual NIC is still limited to bandwidth of single physical port
  - Also called a **port channel** or **Etherchannel**
- With **virtual chassis** or **stacked switch** support from switch vendor, can also handle physical switch outage
- Switches talk to each other to provide load balancing and to add/remove adapters from port group

## Link Aggregation: Port group

- Create an OSA port group

```
SET PORT GROUP PCHNL01 JOIN F100 F200.P1
```

- Create a VSWITCH that references to group

```
DEFINE VSWITCH ...  
        ETHERNET  
        GROUP PCHNL01
```

- Done and dusted!

- Ports cannot be shared with other VSWITCHes or LPARs unless using **shared port groups**

### Suggested Practices

- Name your port groups to match the name of the port channel on the switch
- Put VSWITCH definition in AUTOLOG1 or AUTOLOG2

# Sharing Physical Ports

## Port sharing without Link Aggregation

- No special restrictions
- All operating systems
- VSWITCH and/or dedicated

# Port sharing with link aggregation

## Why?

- If suggested practice is 4 ports per VSWITCH
  - ... and you have a 4-member SSI cluster
  - ... and you have one VSWITCH per member
  - ... and you cannot share ports that are in a link-aggregation port group
  - ... then you need 16 ports (i.e. 16 10Gb OSA-Express features)
- That's  $\frac{1}{4}$  of the port capacity of the machine (and expensive)!

# Port sharing with Link Aggregation

## Global VSWITCH with shared port group

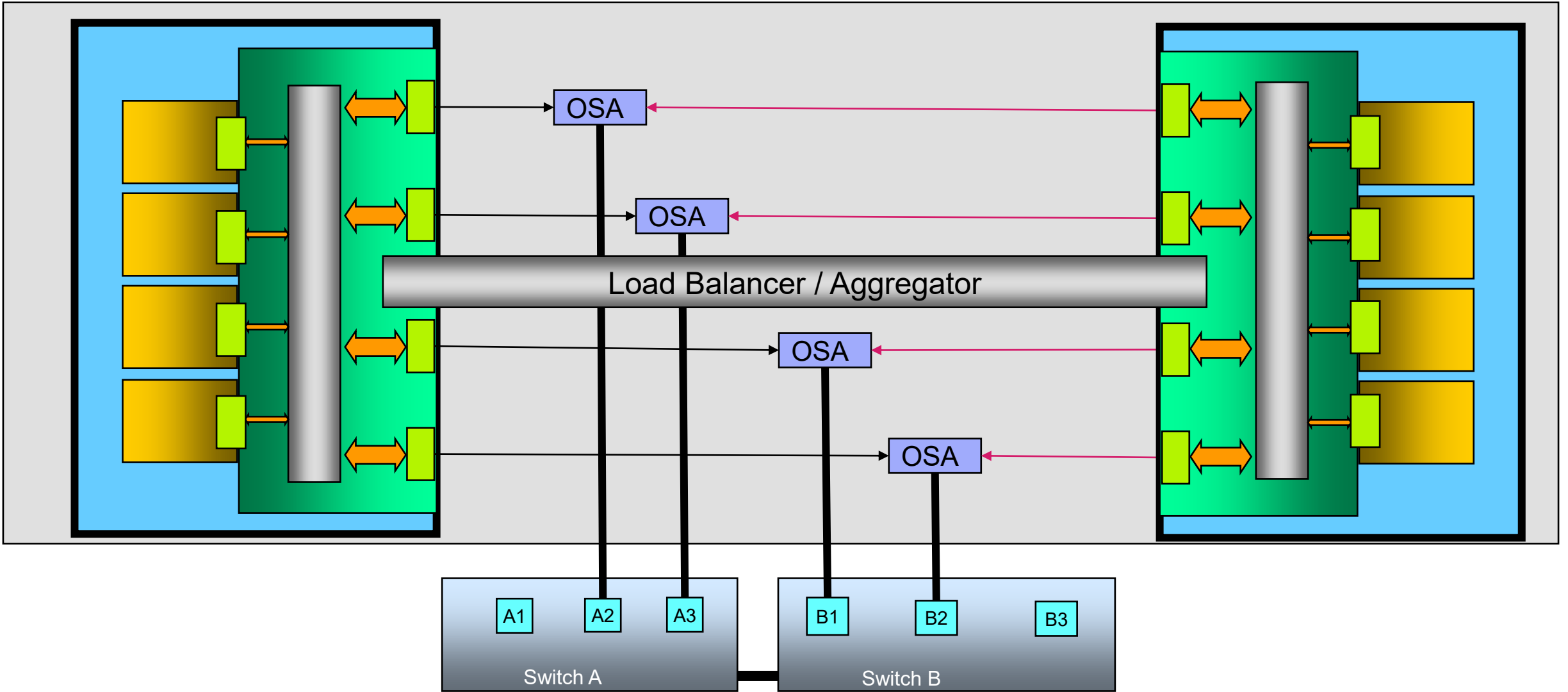

# Shared Link Aggregation Port Groups

— Two new system constructs

- **Global VSWITCH**

- Virtual Switch that spans multiple z/VM LPARs within a single CPC, all using the same link aggregation port group

- **Inter-VSWITCH Link (IVL)**

- Provides data channel for management of shared port groups and the Global VSWITCH
- Each z/VM system is assigned to one **IVL domain** (A – H)
- Up to 16 systems in a domain

— All members of the domain can use a SHARED port

- If not shared, the early bird catches the worm!

— Configuration changes to shared port group or global VSWITCH are propagated to all members of the domain

## Suggested Practice

- One domain for production, another domain for dev/test

# Shared Link Aggregation Port Groups

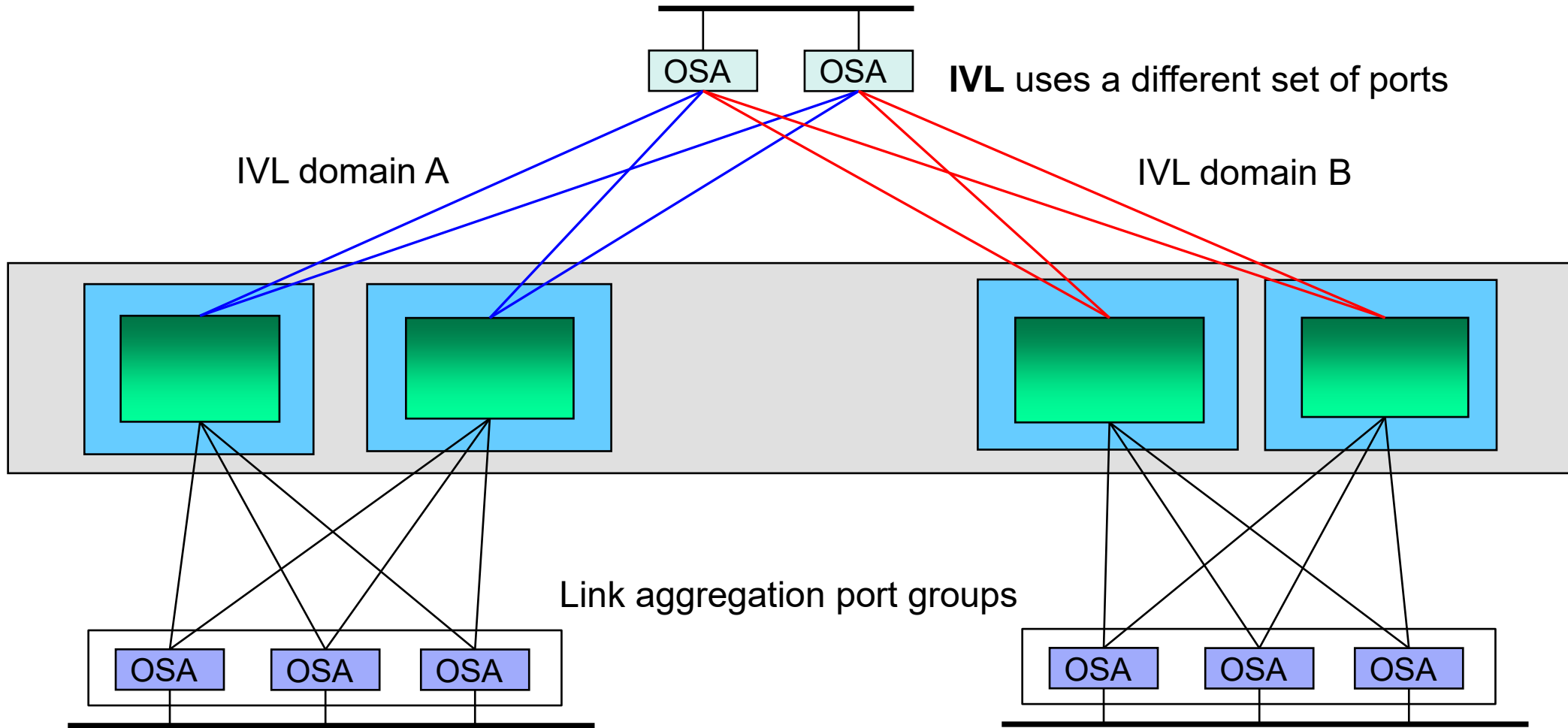

# IVL: Create the IVL VSWITCH

```
DEFINE VSWITCH name TYPE IVL DOMAIN d [VLAN vid]
```

- Conventional RDEV list or exclusive port GROUP
  - Remember to provide OSA port redundancy!
  - **No, the IVL cannot use the same ports that the global VSWITCHes are using as uplinks!**
- Do this on each z/VM that will share the port group
  - Command must be the same on all instances (name, domain, VLAN id)
  - QUERY VSWITCH will show the name as *systemid.name* instead of “SYSTEM *name*”
    - If you have any programs that interpret the output of QUERY VSWITCH, you may need to fix them
- z/VM automatically joins the domain
- Do this before you create a shared port group or global VSWITCH

## Create a shared Port Group

```
SET PORT GROUP name LACP ACTIVE SHARED  
SET PORT GROUP name JOIN rdev1.port rdev2.port ...
```

- Device numbers can be any device number on the chpid
- CP will select the device numbers to be used on the other z/VM instances
- CP propagates changes to the port group configuration to all active members of the IVL domain
- Do this before you create a global VSWITCH

# Create a Global VSWITCH

```
DEFINE VSWITCH name GLOBAL ETHERNET GROUP group
```

- Multiple global VSWITCHes can be defined per z/VM instance
  - All in the same IVL domain
- An *instance* of a Shared Port Group is created when it is configured to a virtual switch

# Create a Global VSWITCH: Example

```
SET PORT GROUP PCHNL032 LACP ACTIVE SHARED
SET PORT GROUP PCHNL032 JOIN 6100 6200
DEFINE VSWITCH VSW1 GLOBAL ETHERNET GROUP PCHNL032
```

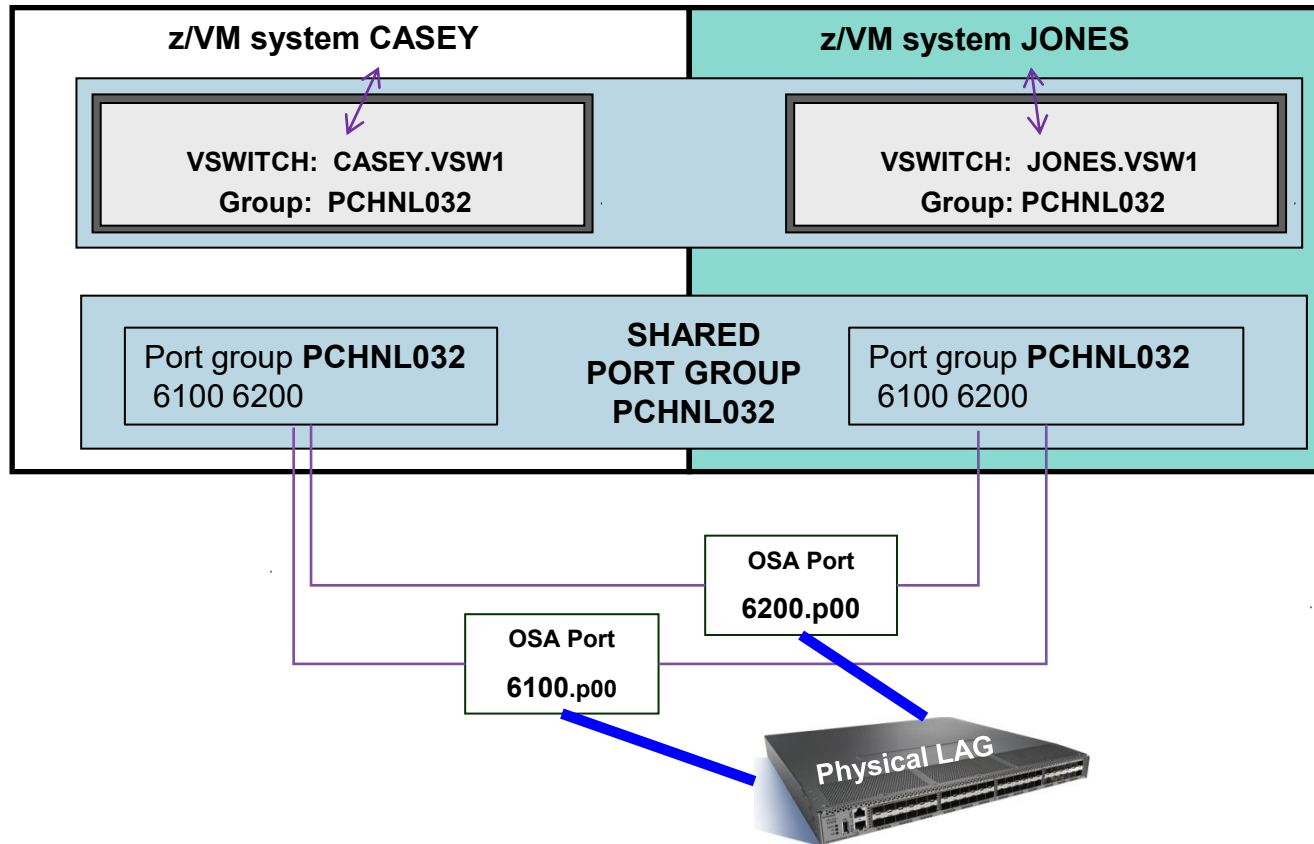

- Up to 4 global VSWITCHes in the same **partition** can share a port group
- A 2<sup>nd</sup> level VSWITCH counts!

## Link Aggregation: Asynchronous Port Group and VSWITCH Initialization

**!ALERT!**

- Guests cannot connect to a VSWITCH until it is defined (virtual NIC errors)
- A VSWITCH using a shared port group will not be defined until the port group is ready
- Shared port group cannot form until IVL "settles"
- The SET PORT GROUP and DEFINE VSWITCH commands will complete asynchronously
- **Placing SET PORT GROUP and DEFINE VSWITCH in SYSTEM CONFIG is not sufficient!**
- If you bring guests up before your VSWITCH is defined, guests will get NIC errors
- Defer guest startup to automation (e.g. IBM Operations Manager) which waits for VSWITCH activation
  - Watch for messages to OPERATOR
  - QUERY-style polling logic

# HiperSocket VSWITCH Bridge

# HiperSocket VSWITCH Bridge

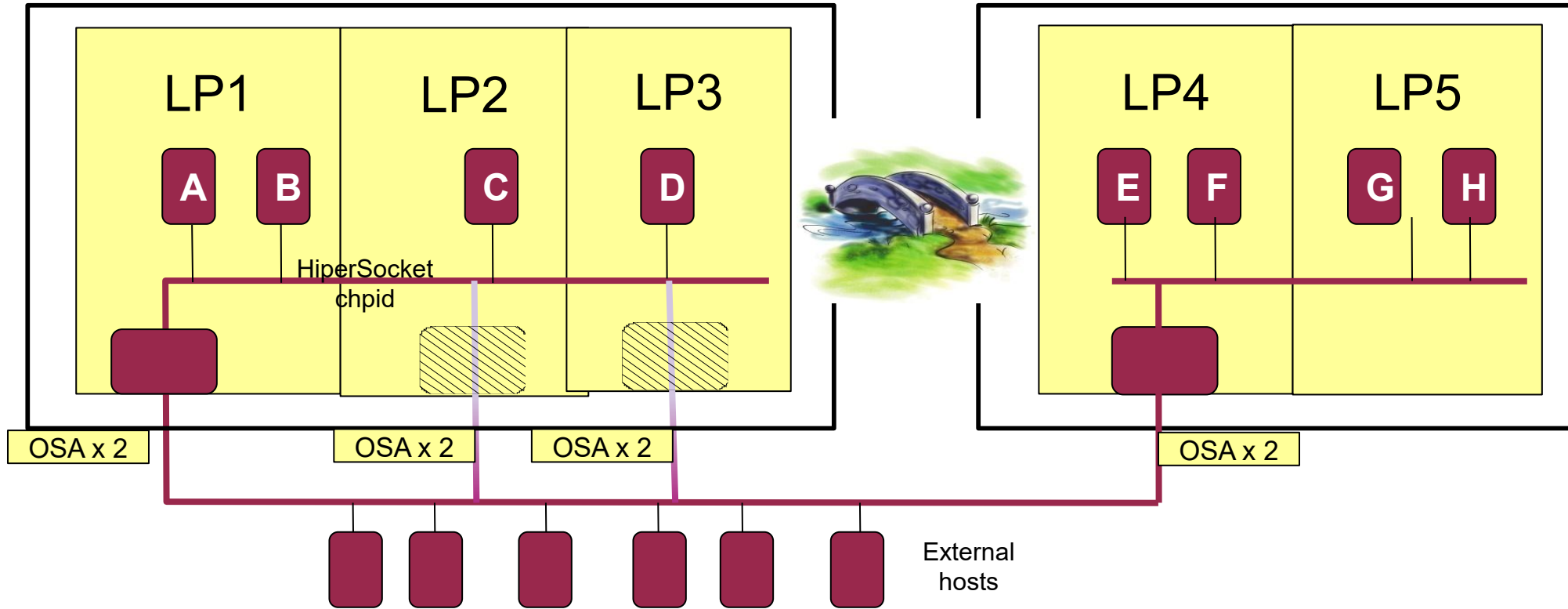

— One active bridge per partition

— Path MTU discovery support

- Large frames inside
- Smaller frames outside

# HiperSocket VSWITCH Bridge

- Connect HiperSocket LAN to ethernet LAN without a router
  - Same subnet as ethernet LAN
- Full redundancy
  - Up to 5 bridges per CPC (CEC)
  - Automatic failover with optional failback
  - Each bridge can have more than one OSA uplink (typical)
- Enables cross-CPC Live Guest Relocation for guests using HiperSockets
- Does not work with z/OS LPARs
  - Look at z/OS HSCI

# HiperSocket VSWITCH Bridge

```
DEFINE VSWITCH ...  
    ETHERNET  
    BRIDGEPORT RDEV hs-rdev  
    [PRIMARY]
```

- I/O configuration change required
  - HiperSocket CHPID must be defined with CHPARM=x4
- The EXTERNAL\_BRIDGED operand is available on CP DEFINE CHPID command if using native z/VM dynamic I/O

# Suggested Practices

1. Use **ETHERNET** mode VSWITCH with link aggregation
2. Do not specify other options on DEFINE VSWITCH unless you study them carefully
  - E.g. PORTTYPE TRUNK (boo! hiss!)
3. Specify **MACPROTECT ON** and **LIMIT TRANSIENT 0** on VMLAN statement in SYSTEM CONFIG
4. VLAN-aware VSWITCH should be defined with **VLAN AWARE NATIVE NONE**
5. Don't use virtual trunk ports – leave guests VLAN-**unaware**
  - Use multiple NICDEFs, each with its assigned VLAN ID
6. Put VSWITCH definitions in AUTOLOG1 or AUTOLOG2
  - Don't use SYSTEM CONFIG – you may need automation assist

# Diagnostics

## — CP QUERY VMLAN

- to get global VM LAN information (e.g. limits)
- to find out what service has been applied

## — CP QUERY VSWITCH ACTIVE

- to find out which users are coupled
- to find out which IP addresses are active

## — CP QUERY NIC DETAILS

- to find out if your adapter is coupled
- to find out if your adapter is initialized
- to find out if your IP addresses have been registered
- to find out how many bytes/packets sent/received

## Diagnostics: Discard Counters

Discard Counter	Uplink: QUERY VSWITCH ACTIVE	Guest NIC: QUERY NIC USER userid vdev
RX > 0 inbound	VSWITCH definition mismatch <ul style="list-style-type: none"><li>• Unused VLAN ID</li><li>• VLAN UNAWARE on trunk</li></ul>	Packets are arriving faster than the guest can consume them
TX > 0 outbound	Overrun on the physical OSA. <ul style="list-style-type: none"><li>• Link is too slow compared to guests</li><li>• Use faster OSA or link aggregation</li></ul>	<ul style="list-style-type: none"><li>• Unauthorized VLAN ID on virtual trunk port</li><li>• Untagged frame on virtual trunk with NATIVE NONE</li><li>• Guest configured as VLAN-aware with virtual access port</li><li>• Overrun target guest</li></ul>
To reset	CP SET VSWITCH COUNTERS CLEAR	Resets when NIC is detached

# Diagnostics: Port Group Verification

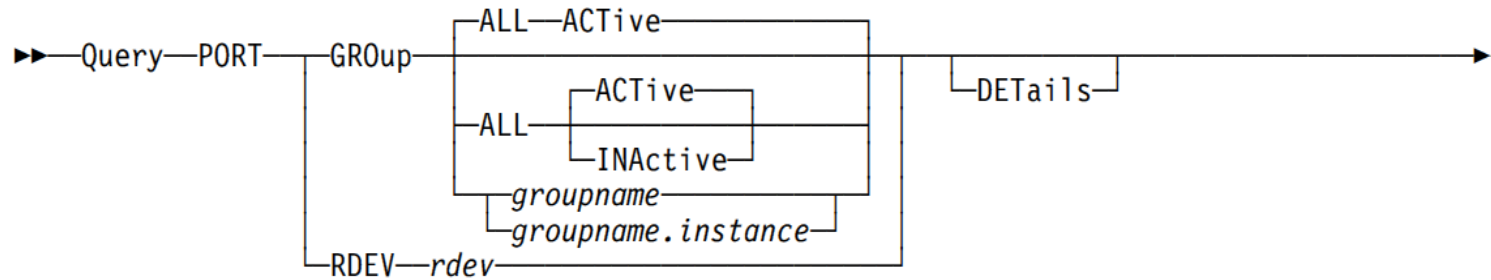

- ALL ACTIVE            All port groups that are associated with a virtual switch
- ALL INACTIVE        All port groups that are not associated with a virtual switch
- *groupname* or *groupname.instance*
  - The specified port group, optionally qualified by instance ID
- RDEV                    Information about the specified real device
- DETAILS                Additional information
- See also SET VSWITCH ... IVLPORt PING for a shared port group

# References

## — HELP command

- `help sysconfig definvsw`      **DEFINE VSWITCH statement in SYSTEM CONFIG**
- `help sysconfig vmlan`      **VMLAN statement in SYSTEM CONFIG**
- `help define vswitch`      **CP DEFINE VSWITCH command**
- `help cpset port`      **CP SET PORT GROUP command**
- `help directory nicdef`      **NICDEF statement in user directory entry**

## — Publications:

- z/VM CP Planning and Administration
- z/VM CP Command and Utility Reference
- z/VM Connectivity

# Experience more with IBM



## Visit us at the IBM Booth #113

After a full day of technical sessions, take a break with us!

Connect with our experts, snap a photo with the z17 Plexi or the latest Telum II, and get an up-close look at our Spyre Accelerator.

Come back each day for fresh topics and demos at our expert stations.

## Think 2026

Join 5000+ senior business and technology leaders who are seizing the AI revolution to unlock unprecedented growth and productivity at **Think 2026**.

Find out more information using the QR code below.



## IBM Digital Asset Haven

IBM Digital Asset Haven is the operational backbone for financial institutions and regulated enterprises entering the digital asset economy.

Find out more information using the QR code below.

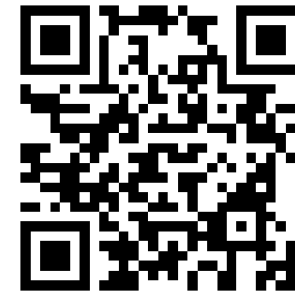

# Contact Information

**Alan Altmark**

*Senior z/VM Engineer and Consultant*

IBM Infrastructure  
z/VM Development

**IBM**

*1701 North Street  
Endicott, NY 13760*

*Mobile 607 321 7556*

*Email: [Alan\\_Altmark@us.ibm.com](mailto:Alan_Altmark@us.ibm.com)*